

United States Army Warfighting Center
Fort Rucker, Alabama
OCTOBER 2005



STUDENT HANDOUT

TITLE: CH-47D POWER PLANTS

FILE NUMBER: 011-2107-5

PROPONENT FOR THIS STUDENT HANDOUT IS:

110th Aviation Brigade
ATTN: ATZQ-ATB-AD
Fort Rucker, Alabama 36362-5000

FOREIGN DISCLOSURE RESTRICTIONS: This product/publication has been reviewed by the product developers in coordination with the Cargo Utility Branch/ Ft. Rucker foreign disclosure authority. This product is releasable to students from all requesting foreign countries without restrictions.

CH-47D POWER PLANTS

STUDENT HANDOUT

TERMINAL LEARNING OBJECTIVE (TLO):

Action: Describe components, operational characteristics, functions, and limitations of the CH-47D T55-L-712 Power Plant.

Conditions: In a classroom, given a CH-47D Engine N1 Control Trainer, a CH-47D Engine Controls Trainer, a T55-L-712 Engine Cutaway, and a student handout.

Standards: Correctly answer in writing, without reference, seven of ten questions pertaining to components, operational characteristics, limitations, functions, and malfunctions of the CH-47D T55-L-712 Power Plant, In Accordance With (IAW) TM 1-1520-240-10 and the student handout.

Safety Requirements: None.

Risk Assessment Level: Low.

Environmental Considerations: None

Evaluation: Each student will be evaluated on this block of instruction during the first written examination. This will be a criterion type examination requiring a GO on each scored unit. You will have 120 minutes for the exam.

1. Learning Step/Activity 1-Describe operational characteristics of the Power Plant.

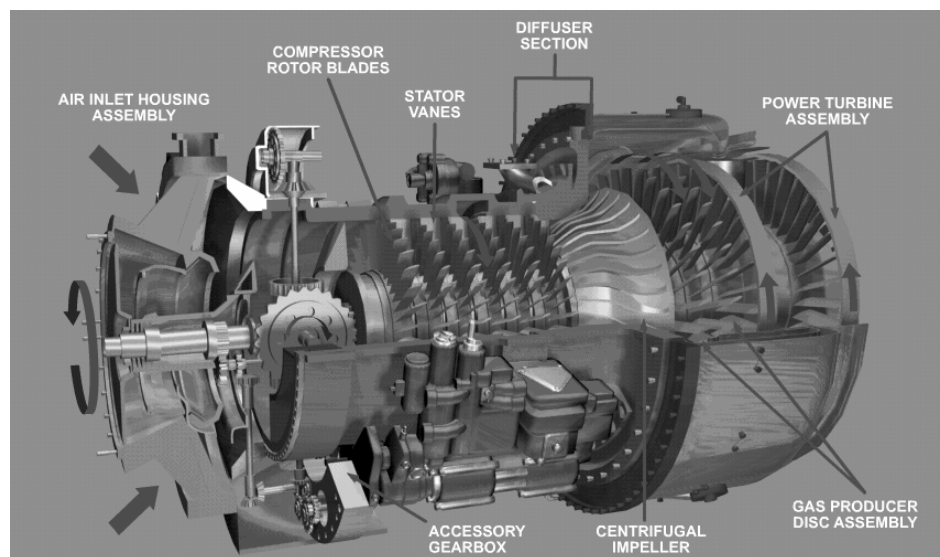

- a. General description of the power plant.
 - (1) Type, Model, and Series: T55-L-712.

- (2) Maximum shaft horsepower (SHP) for 10 minutes: 3,750.
- (3) Maximum SHP for actual emergencies: 4,500.

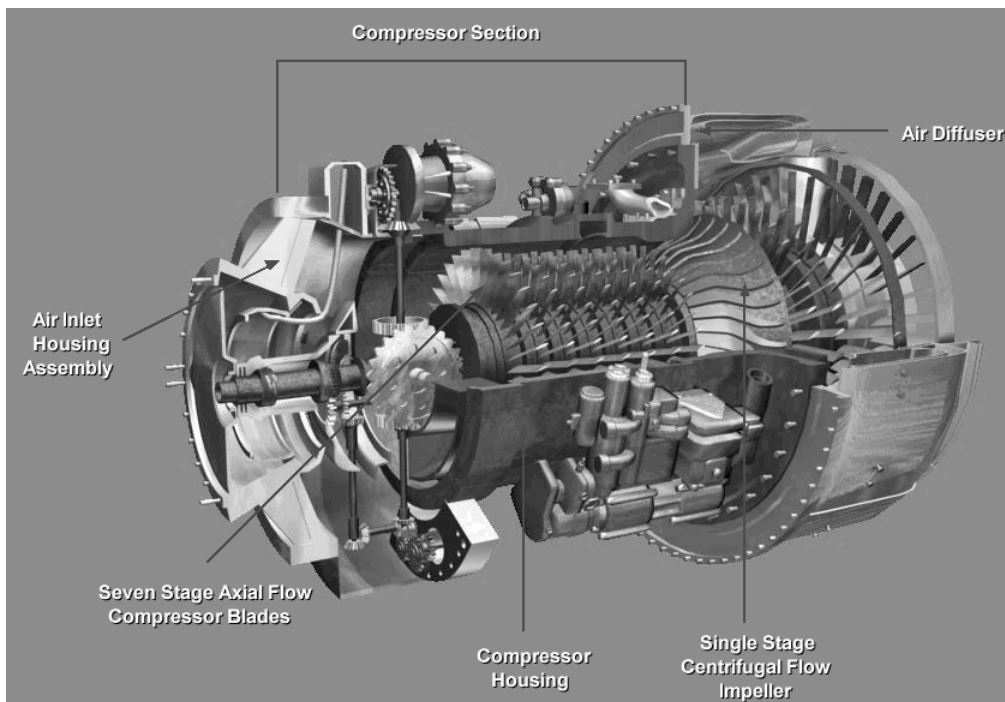
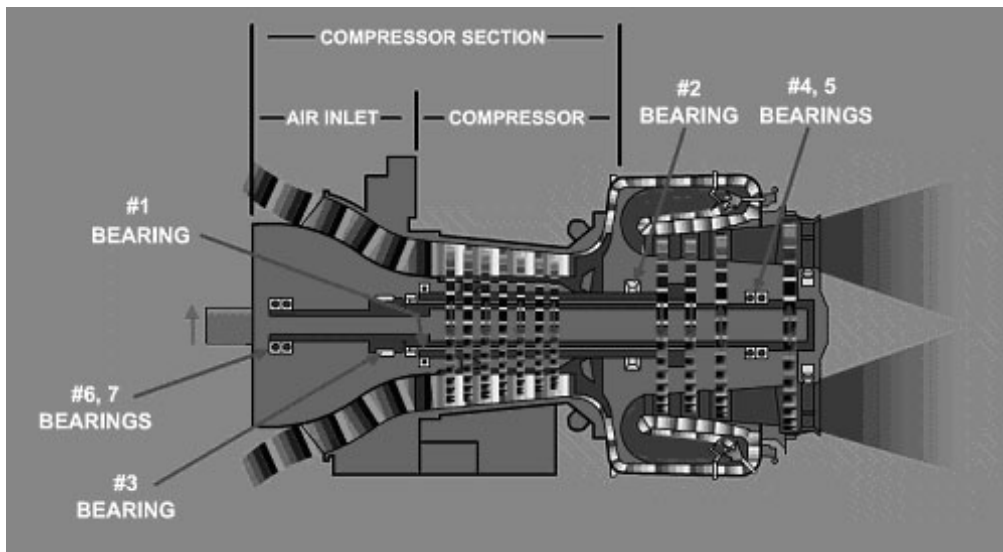

b. Engine sections.

- (1) Compressor section.
 - (a) Supplies air for combustion and cooling.
 - (b) A seven stage axial and a single stage centrifugal flow design.

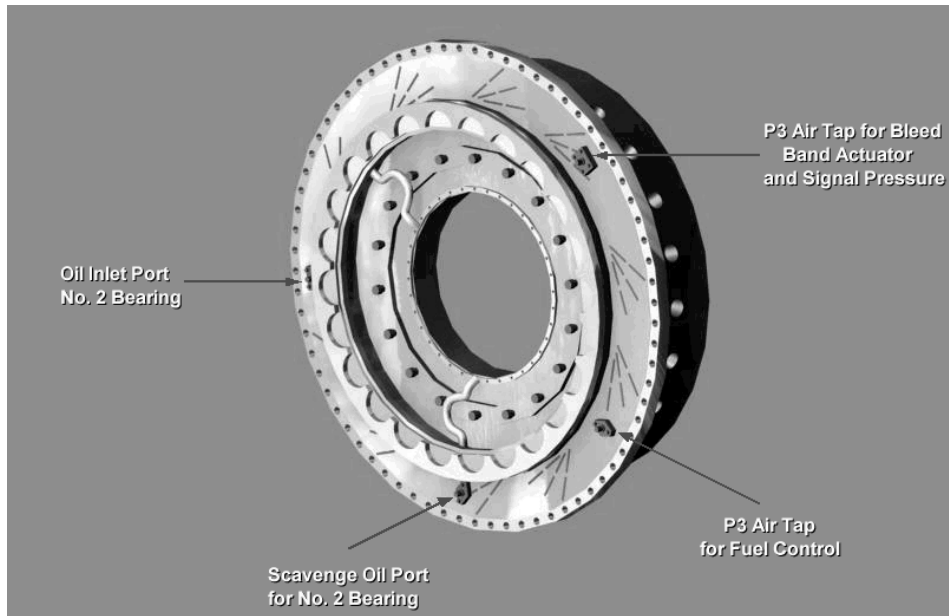

(c) Compressor interstage airbleed system.

- 1) Located at the sixth stage of compression.
- 2) Partially unloads the compressor during power changes to allow rapid acceleration and prevent compressor stalls.

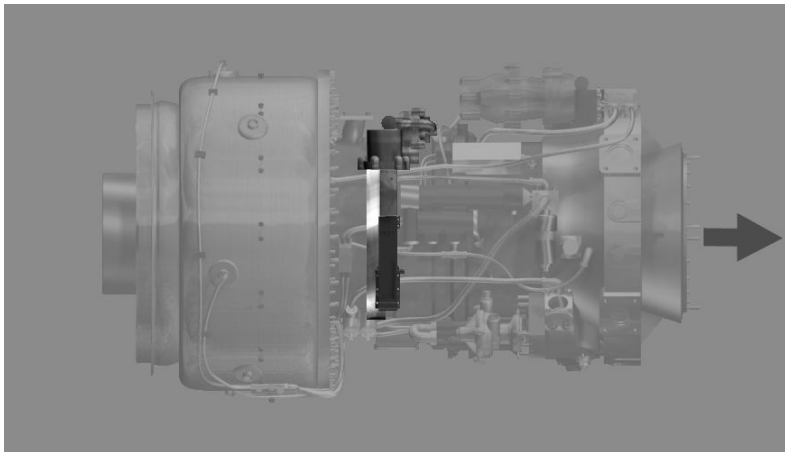

- 3) Operated by a pneumatic actuator.
- 4) Controlled by the fuel control in response to the following:
 - a) Fuel flow.
 - b) N_1 speed.
 - c) P_3 air pressure.

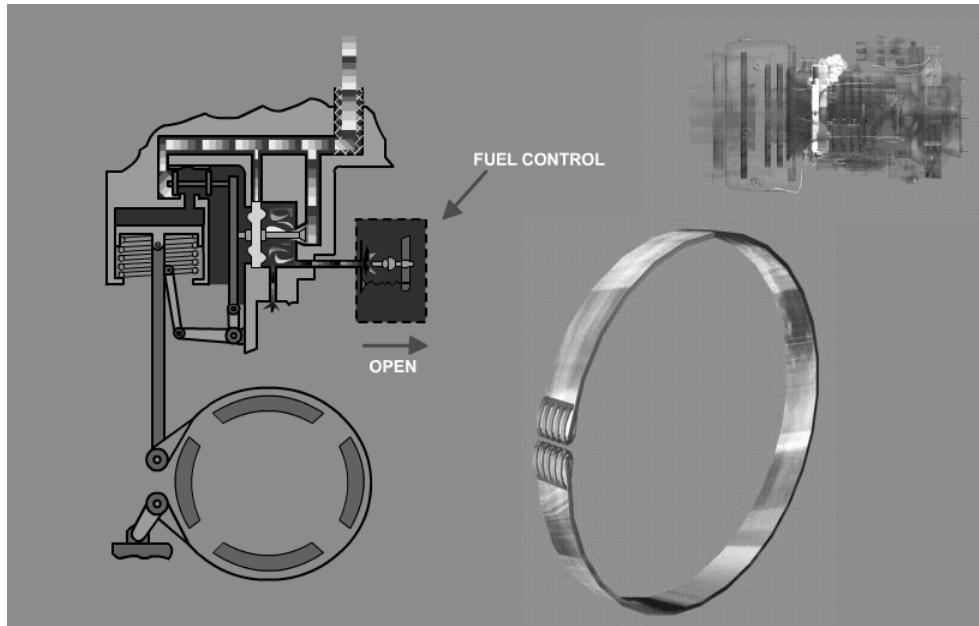

5) Bleed band popping.

- a) Indicated by fluctuations in torque, Power Turbine Inlet Temperature (PTIT), and noise.
- b) To reduce or eliminate bleed band popping, **reduce power.**

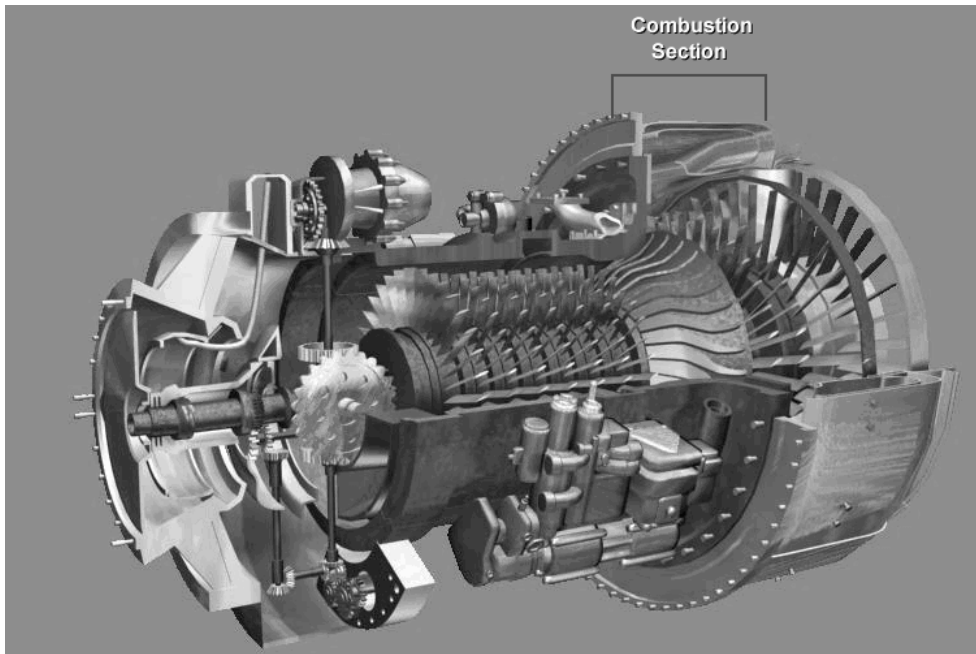

(2) Combustor section.

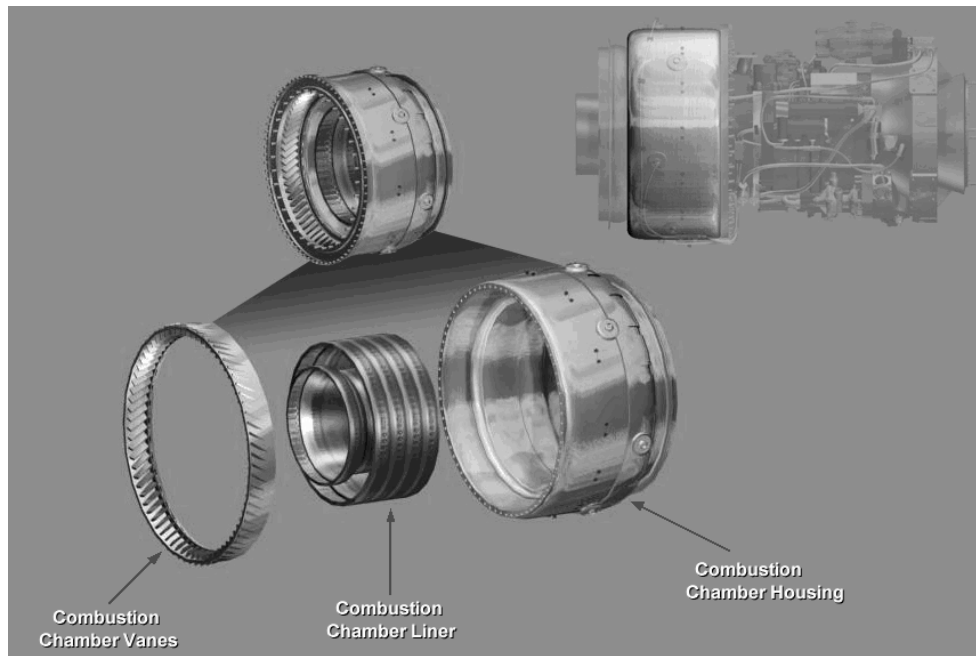

(a) Air is mixed with fuel for combustion.

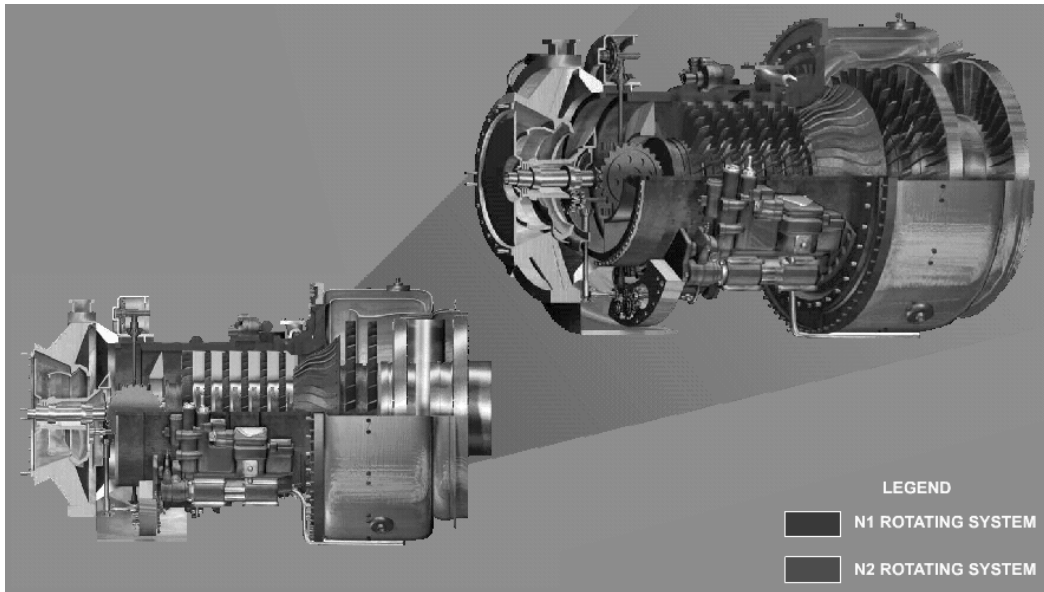

- (b) Gas producer (N_1) turbines extract energy from the hot gases to drive the compressor and N_1 accessories.
- (c) Power turbines (N_2) extract the energy from the hot gases to drive the rotors through the transmission and drive system.

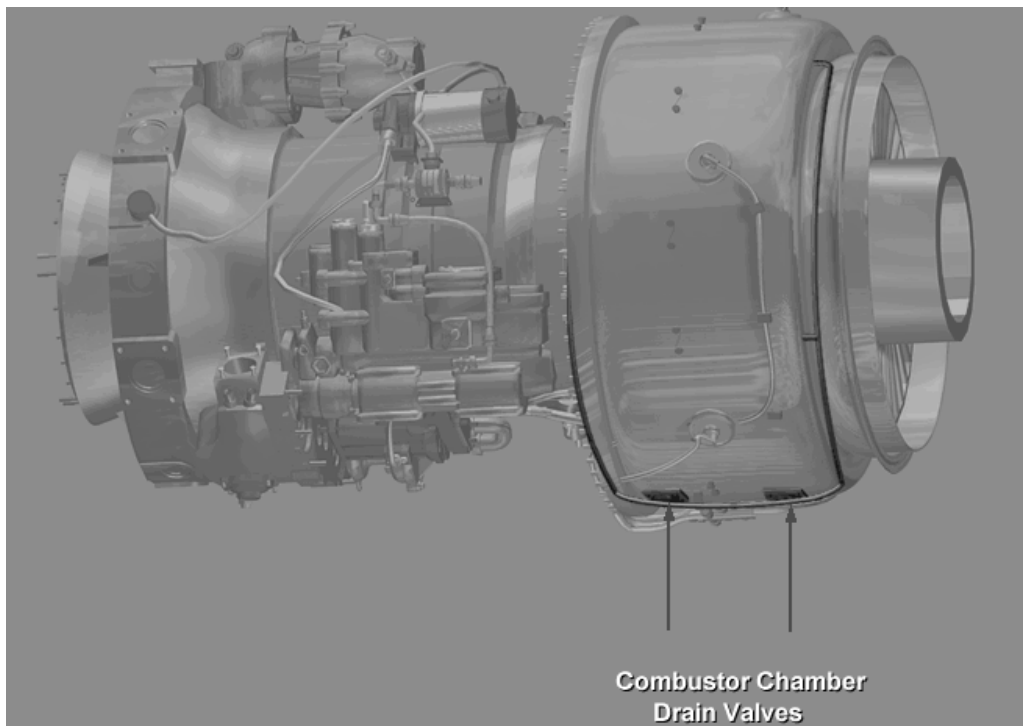

- (d) Combustor drain valves.
 - 1) Located at the bottom of the combustor.
 - 2) Spring loaded open and closed by internal air pressure.

2. Learning Step/Activity 2–Describe Engine Subsystems.



- a. Gas producer (N_1) tachometer.
 - (1) Indicates the gas producer speed in percent (%).
 - (2) Indicator scales.
 - (a) Outer scale – 0 to 100% in increments of 2.
 - (b) Vernier scale – 0 to 10% in increments of 1.

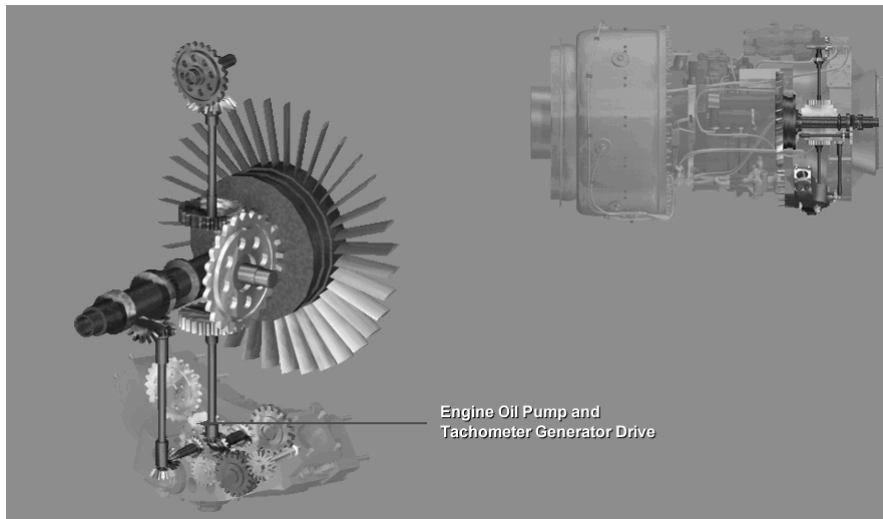

- (3) Tachometer generator.
 - (a) This is mounted on the rear of the engine oil pump.
 - (b) Supplies a frequency signal proportional to N_1 speed to the instrument.

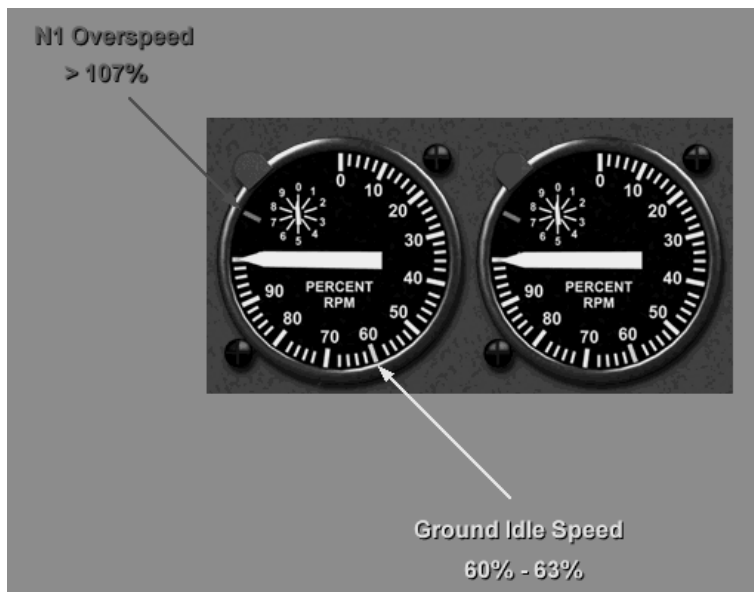

- (4) N_1 overspeed.
 - (a) When **107%** is exceeded.
 - (b) May cause an over-temperature and/or over-torque.
 - (c) Ground idle speed: **60 to 63%**.

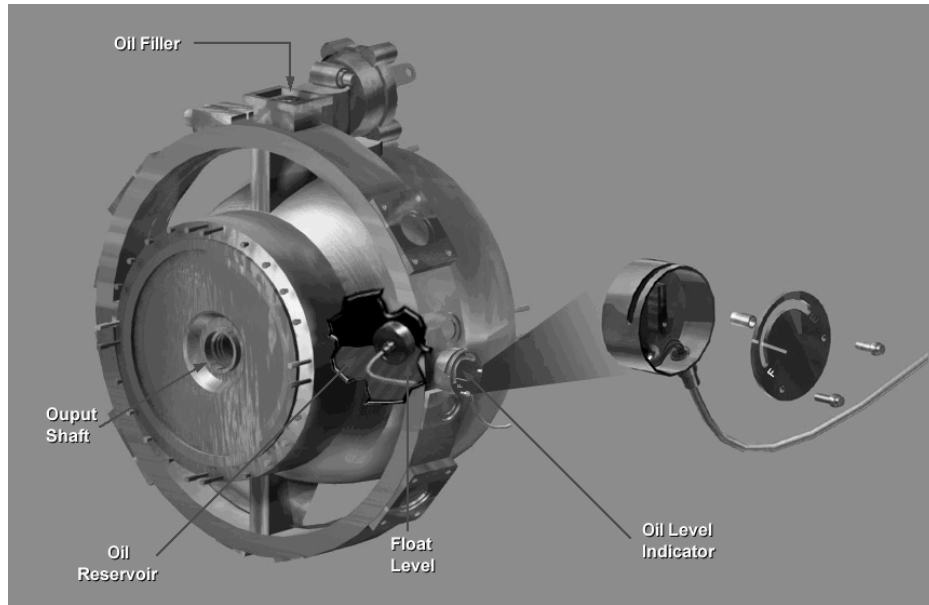

b. Lubrication system.

(1) Integral oil tank.

- (a) The tank is located in the inlet housing.
- (b) Check that the filler cap is secure and the tab is positioned aft.
- (c) System capacity is **14** quarts, leaving room for expansion.
- (d) Types of oil used.
 - 1) MIL-L-23699, when temperatures are above -32° C.
 - 2) MIL-L-7808 when temperatures are below -32° C.
 - 3) If the oils are mixed, the system must be flushed within **6** hours of operation, an oil sample taken, and a -13 entry made.

(2) Oil level indicator.

- (a) Is located on the left side of the engine inlet section.
- (b) If the oil level is low and the engine has been shutdown for more than 24 hours, run it up, shut down, and recheck.
- (c) The indicator incorporates a switch to activate the ENG OIL LOW caution light.



(3) NO.1 ENG OIL LOW / NO.2 ENG OIL LOW caution lights.

(a) Indicates that approximately **two** quarts of usable oil remain in that engine.



(b) Essential DC bus electrical power through the CAUTION PNL circuit breaker.

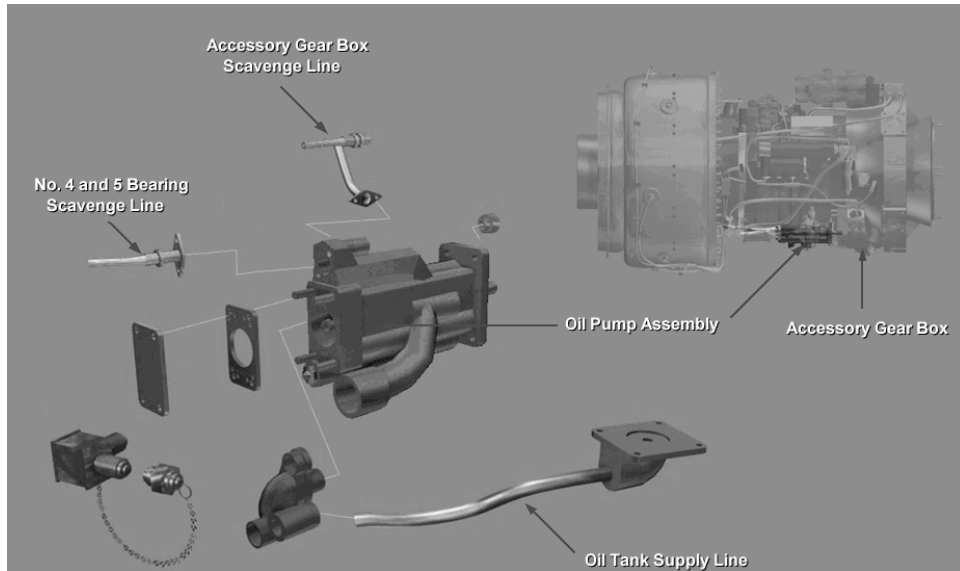

(4) Oil pump.

- (a) The pump is located on the Accessory Gear Box (AGB).
- (b) It contains 1 pressure and 2 scavenge elements.

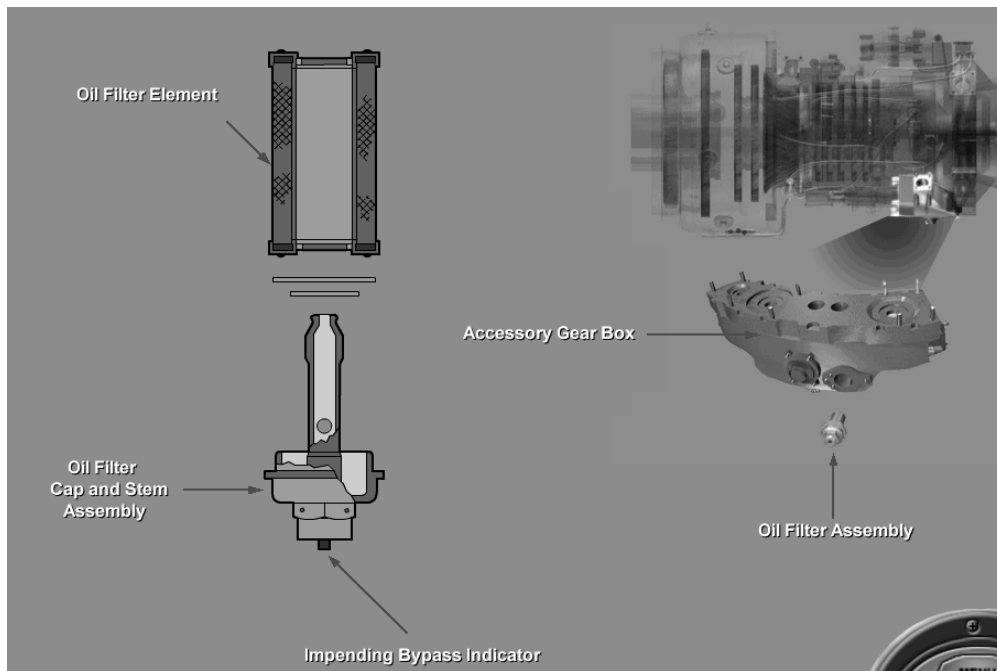

(5) Oil filter.

- (a) Located on the AGB.
- (b) Contains an impending bypass indicator (red button).

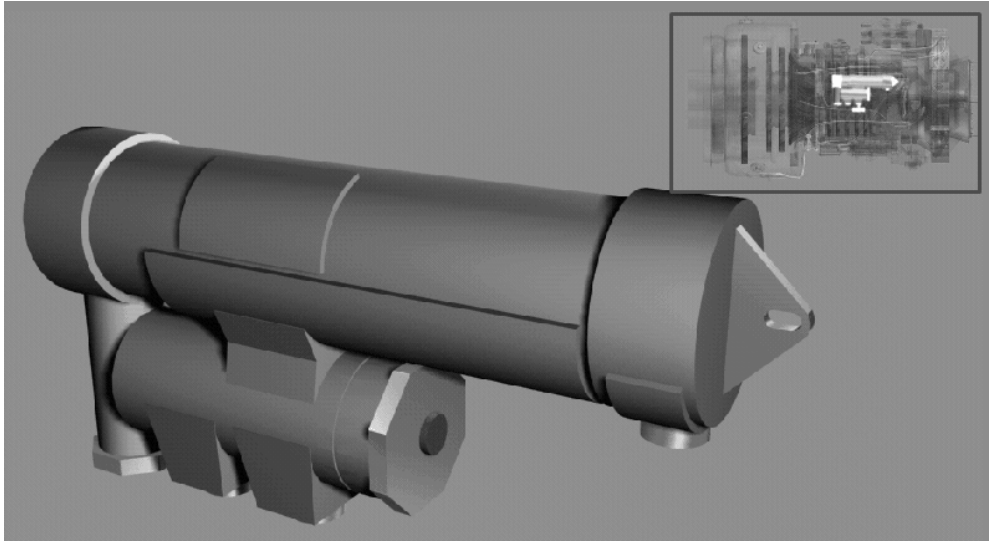

(6) Oil cooler.

- (a) This is the primary method of cooling the oil.
- (b) Fuel flows through the inner tubes, and engine oil flows around the tubes.
- (c) A bypass valve allows oil to bypass until the oil temperature reaches 80° to 100°F. The bypass valve will also allow the oil to bypass when the pressure exceeds 35 PSID (Pounds per Square Inch Differential).

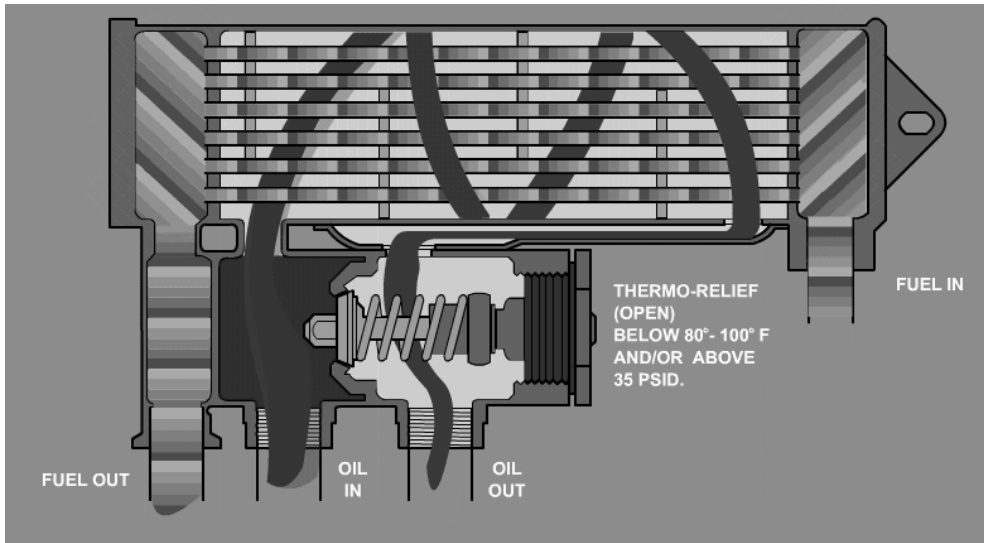

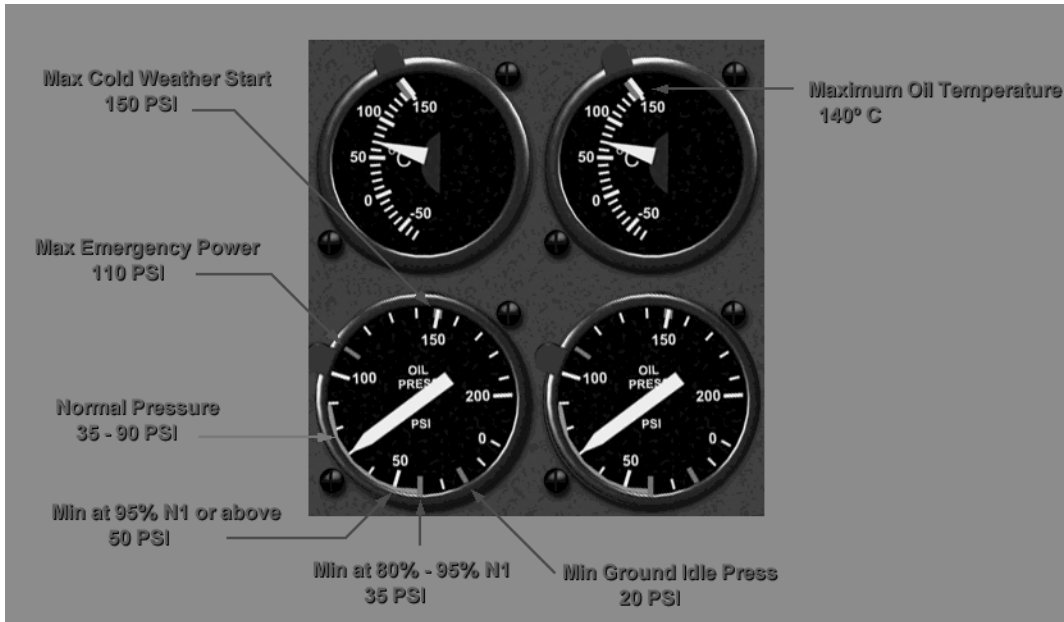

(7) Oil pressure indicator.

- (a) Indicates engine oil pressure at the No.2 bearing.
- (b) The pressure transmitter sends the pressure reading to the cockpit indicator.
- (c) Oil pressure limitations.

| | |
|-----------------|---------------------------------|
| 1) 20 PSI | Minimum at ground idle |
| 2) 35 PSI | Minimum at 80 to 95% N1 |
| 3) 50 PSI | Minimum at 95% N1 or above |
| 4) 35 to 90 PSI | For Normal operation |
| 5) 110 PSI | Maximum at emergency power |
| 6) 150 PSI | Maximum for cold weather starts |

(8) Oil temperature indicator.

- (a) A temperature bulb in the AGB measures the temperature prior to the cooler.
- (b) Maximum oil temperature is 140°C.

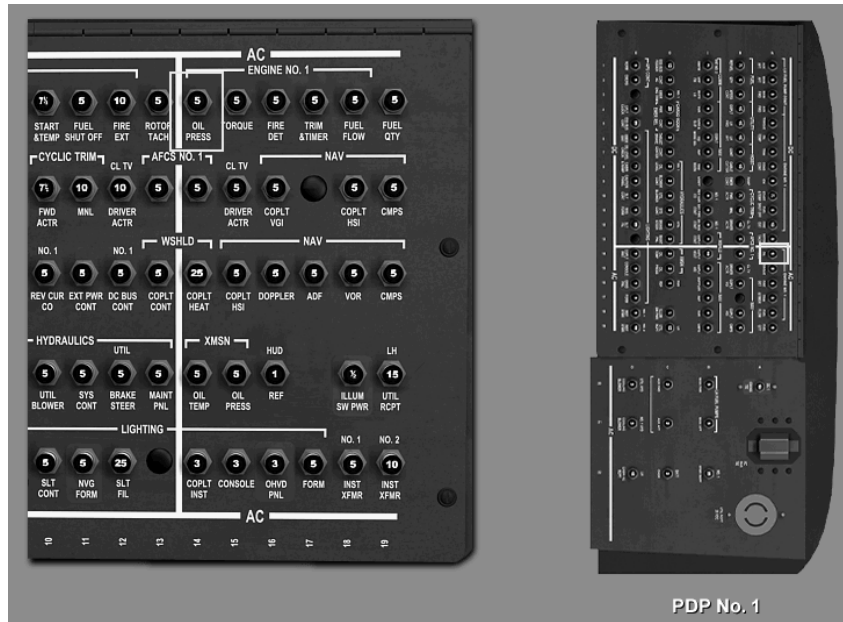

- (c) Electrical power is from the 26 volts AC (VAC) instrument buses through the ENGINE OIL PRESS circuit breakers on both power distribution panels (PDP's).
- (d) No.1 and No.2 DC buses through the ENGINE OIL TEMP circuit breakers.



- (9) ENG CHIP DET caution lights.
- (a) Two lights located on the master caution panel, one for each engine.
- (b) The lights will illuminate if chips are detected in the **engine** or the **engine transmission**.

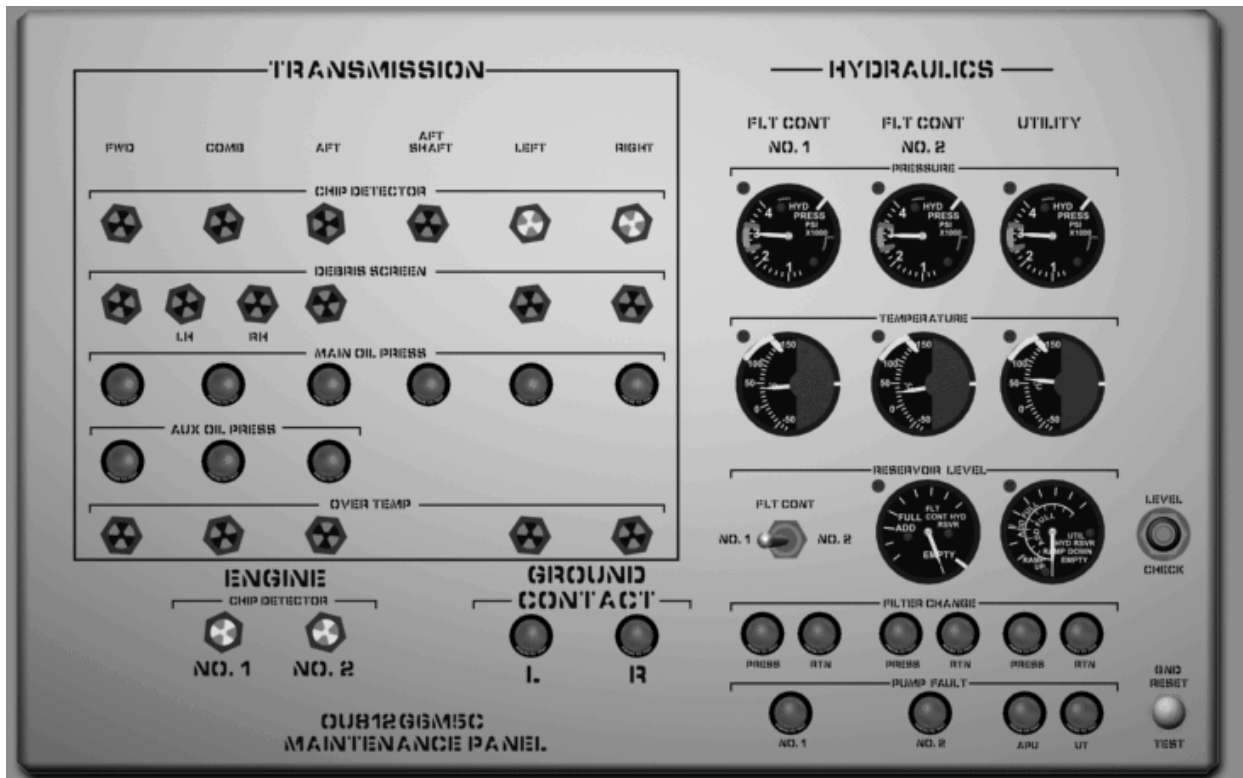

If ENG CHIP DET caution light, determine if from:

- Engine or
- Engine Transmission.

- (10) Magnetic latch indicators.
- (a) The latch indicators are on the maintenance panel.
 - (b) Indicates the location of metal particles (engine or transmission).
 - (c) **Crew member** will identify chip location (eng or eng transmission).

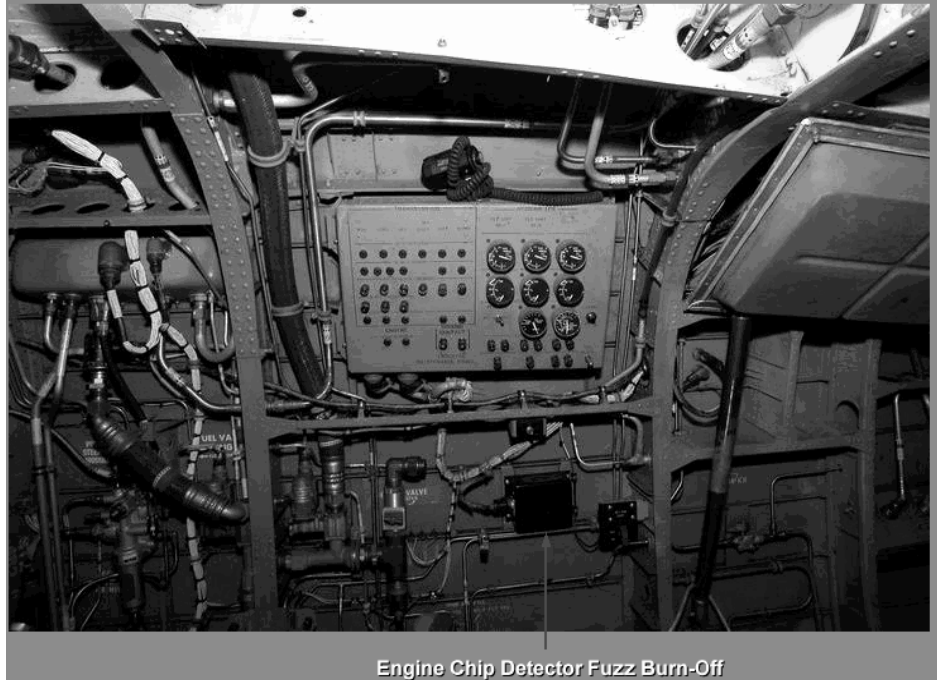

- (11) Engine chip detector fuzz burn-off. A module labeled PWR MDL CHIP BURN-OFF is located below the maintenance panel. This module monitors for the presence of ferrous particles on the **engine accessory gear box**. A successful burn-off will be accomplished before any caution capsule on the master caution capsule illuminates.

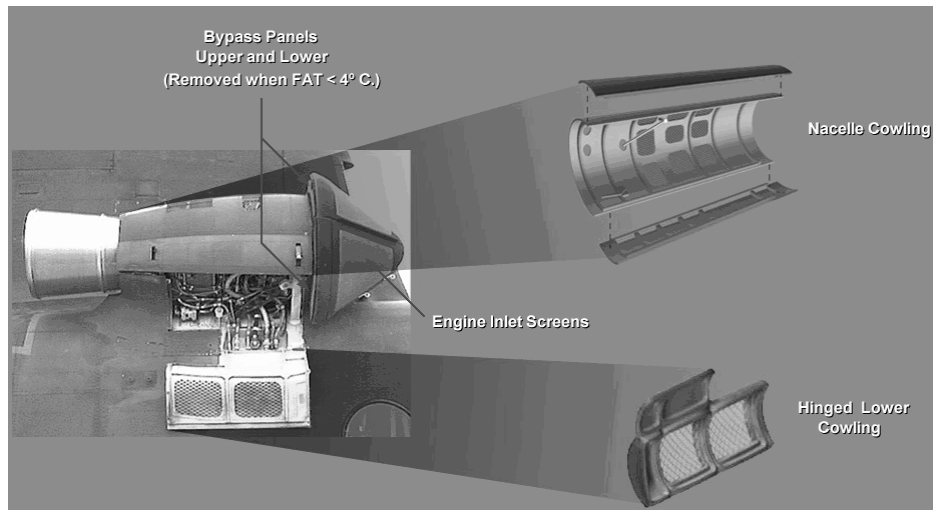

- c. Engine inlet screens.
- (1) The engine cowlings may be opened with the screens installed.
 - (2) To inspect the compressor inlet section, open the lower section of the screen.

(3) Bypass panels. These panels are installed at the aft end of each screen.

NOTE: Refer to current operator's manual for engine bypass panel removal.

Pg:

d. PTIT indicators.

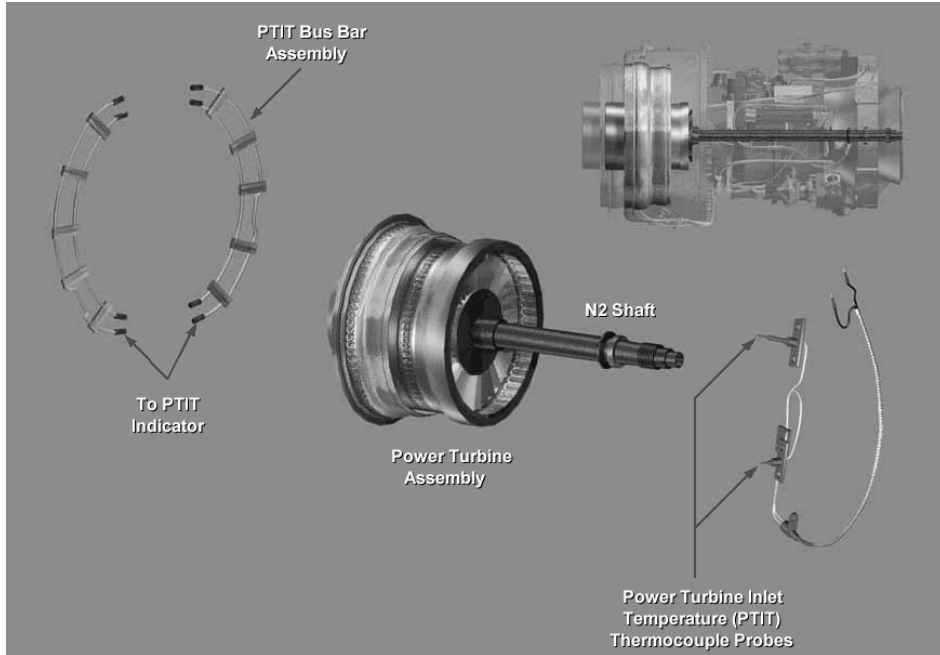

(1) Ten thermocouples sense the temperature at the power turbine inlet and transmit an average reading to the cockpit.

(2) Markings are provided to indicate power range or time limited operations.

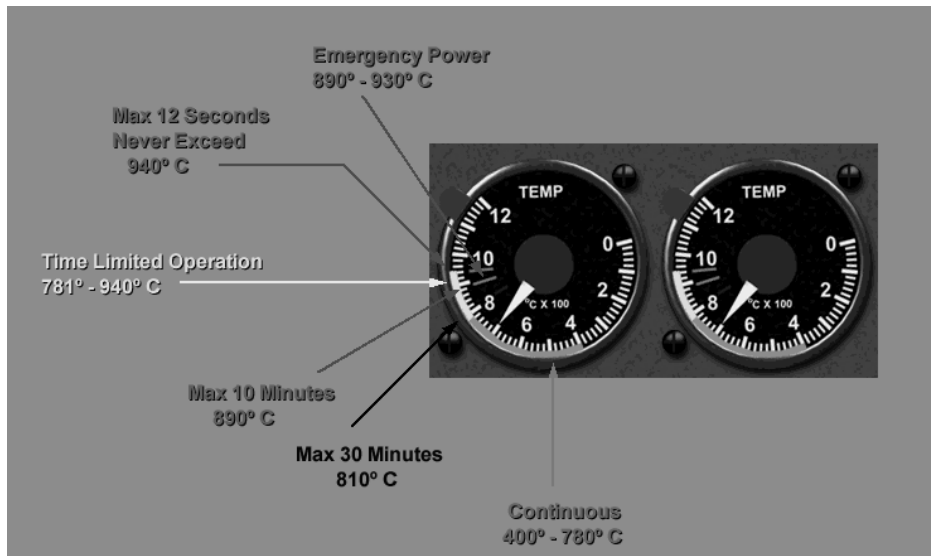

(a) Continuous 400°C to 780°C.

- (b) 30 Minute 810°C
- (c) 10 Minute 890°C
- (d) Emergency power 890°C to 930°C
- (e) 12 Seconds Never Exceed 940° C

(3) Electrical power is through the No.1 and No.2 Essential DC buses through the engine START and TEMP circuit breakers.

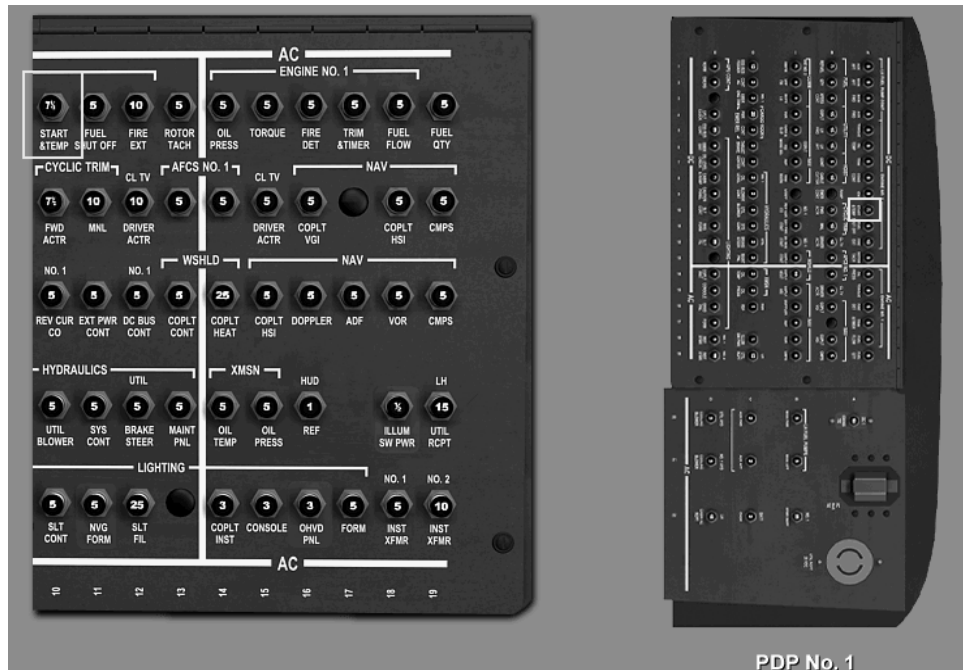

NOTE: Refer to operator’s manual Ch. 5 for additional power limits.

NOTE: **A -13 entry is required when any Chapter 5 limitation has been exceeded!** Note the limit or limits exceeded, range, time above limits, and any additional data that would aid maintenance personnel. Ref: Appendix C, Operator’s Manual.

e. Engine fuel system.

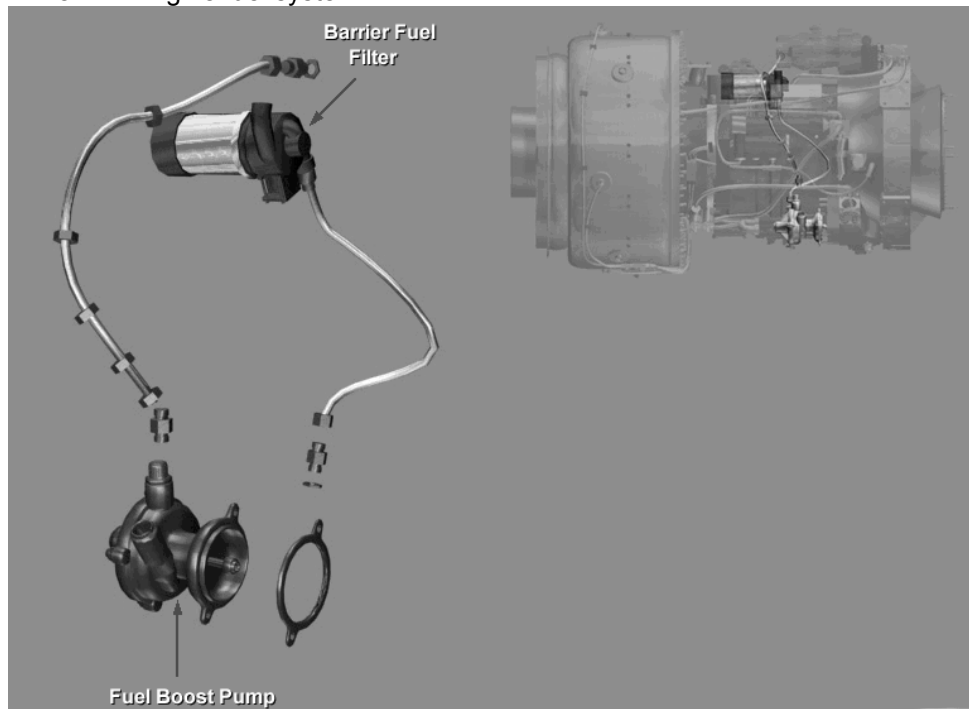

- (1) Engine driven fuel pump.
 - (a) A centrifugal pump driven by the N_1 accessory gear box.
 - (b) Increases fuel pressure up to 20 pounds per square inch (psi) dependent upon engine speed.
 - (c) Draws fuel from the **main** fuel tank below **6,000** feet PA, if the main fuel tank boost pumps fail.
- (2) Static fuel filter.
 - (a) A replaceable paper type cartridge.
 - (b) Bypass provisions if the filter becomes clogged.
 - (c) Impending bypass indicator (red button).

(3) Fuel control unit.

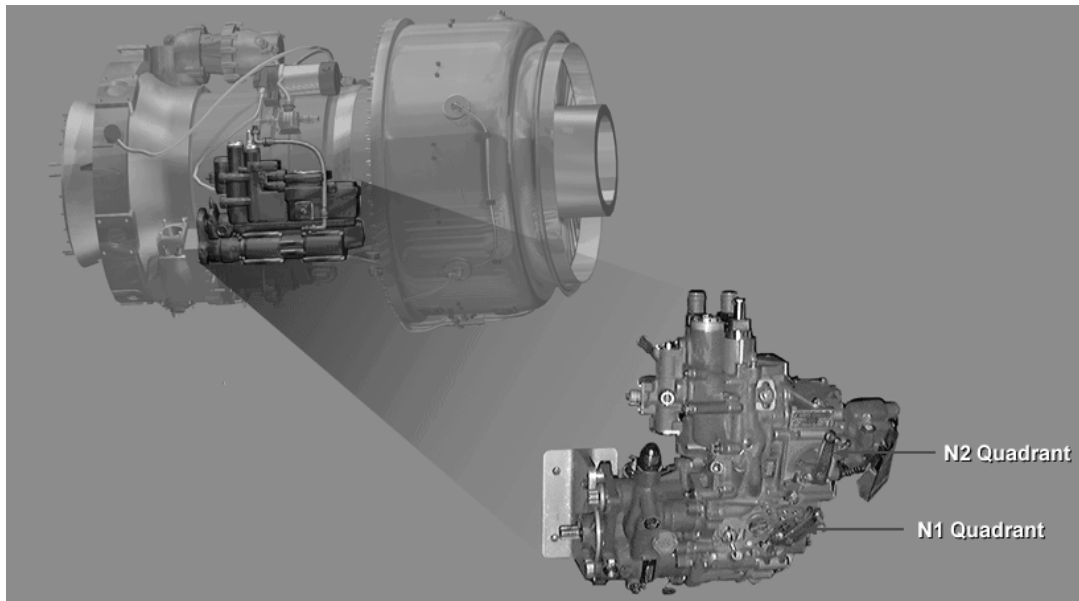

- (a) An internal fuel pump is used to increase fuel pressure.
- (b) Internal shutoff valve to shutoff fuel to the engine, when ECL is moved to STOP.
- (c) The fuel control schedules flow in response to the following:
 - 1) Gas producer (N_1) governor, driven by the compressor.
 - 2) Power turbine (N_2) governor, driven by the power output shaft.
 - 3) Compressor discharge pressure.
 - 4) Compressor inlet temperature.
- (d) If the N_2 governor fails:
 - 1) The engine will automatically accelerate to maximum power.
 - 2) Engine speed **must** be reduced and controlled by reducing the N_1 governor setting (ECL).

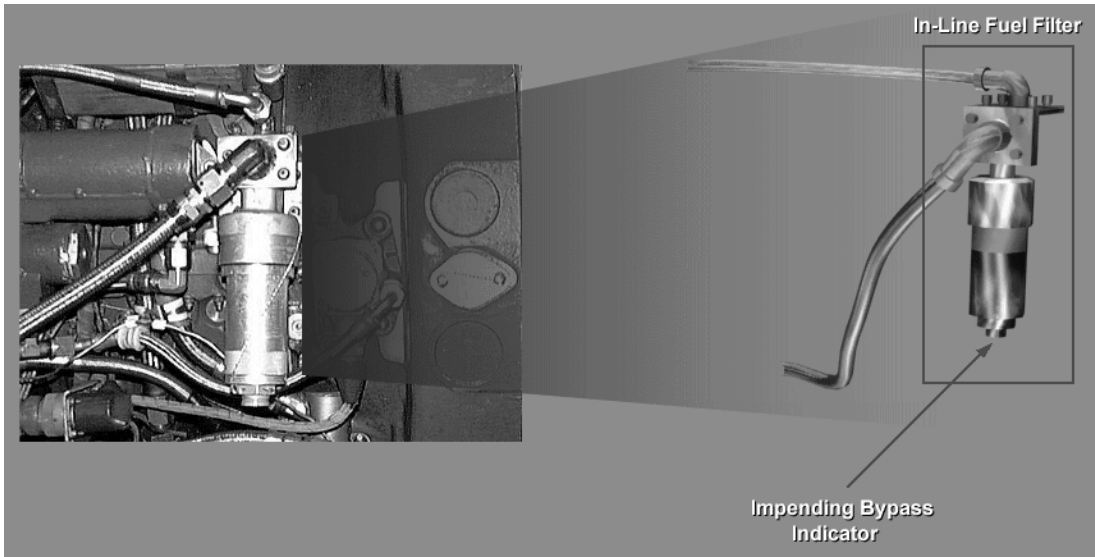

- (4) The in-line fuel filter is located at the two o'clock position on each engine and contains an impending bypass indicator (red button).

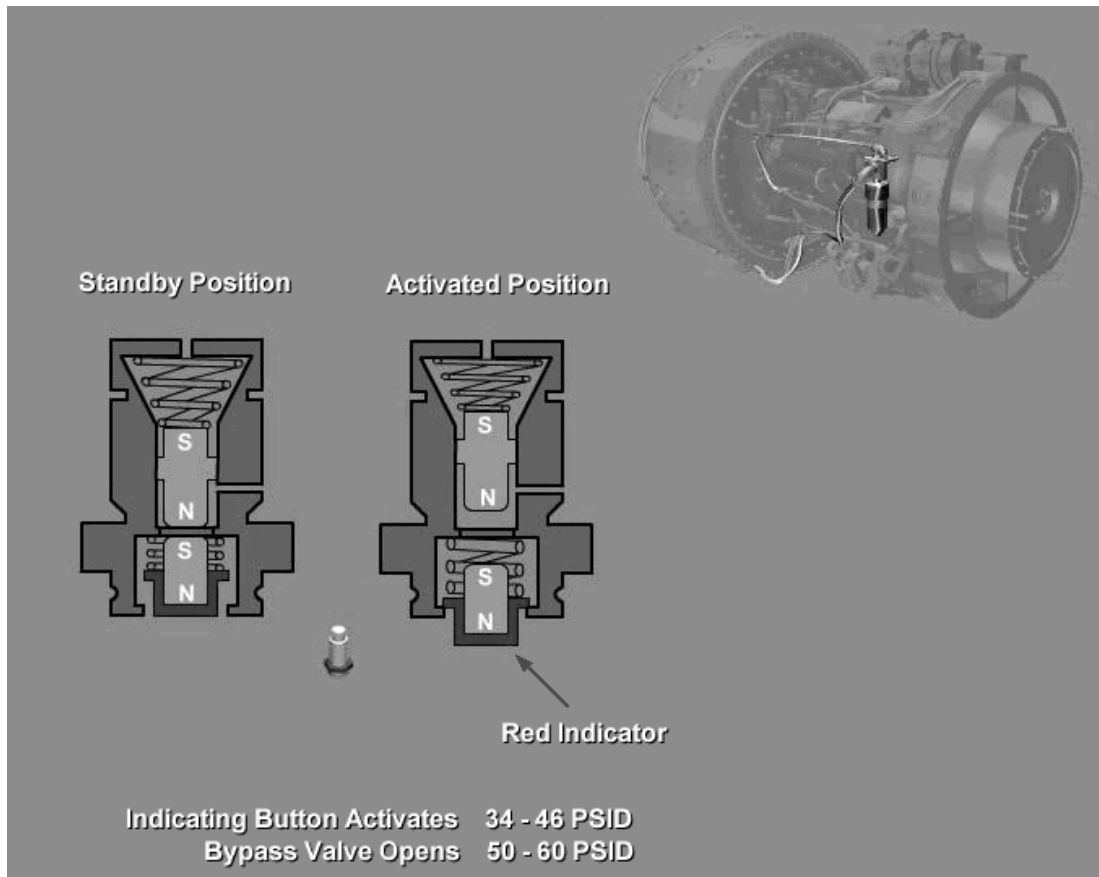

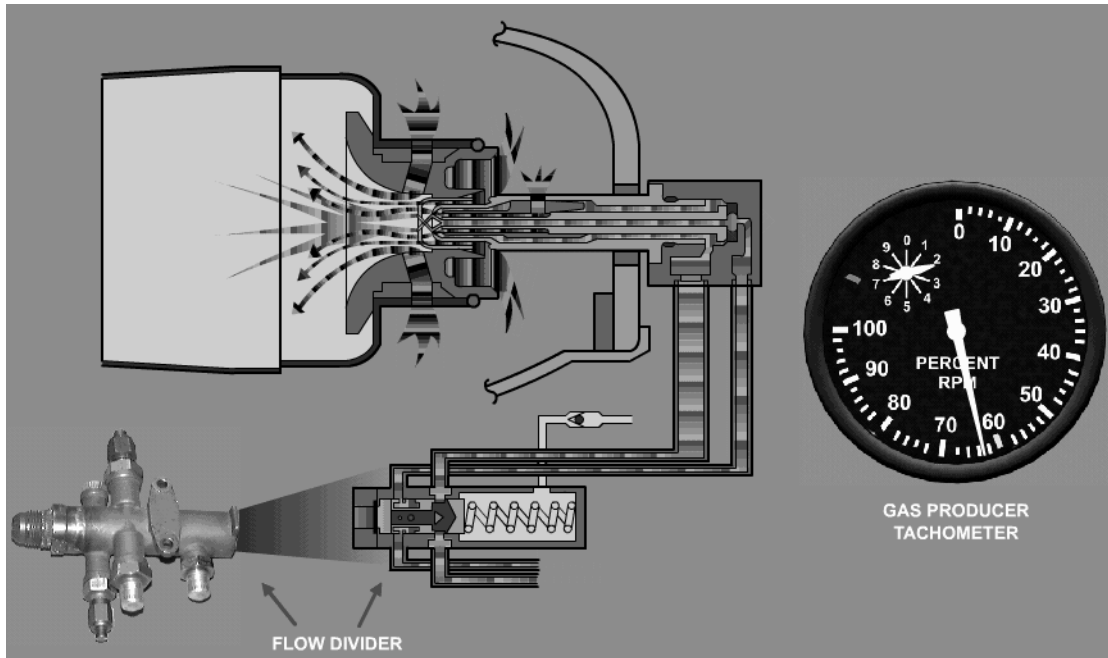

- (5) Fuel flow divider. Located at the five o'clock position on the combustor.
 - (a) Primary fuel is delivered at 8 to 12% N_1 speed.
 - (b) Secondary fuel is delivered a 30 to 32% N_1 speed.
 - (c) This also drains manifold fuel back to the engine driven pump on shutdown.

- (6) Fuel manifold.
 - (a) Dual fuel passageways are provided within the fuel manifold, a primary and secondary.
 - (b) There are 28 fuel nozzles.

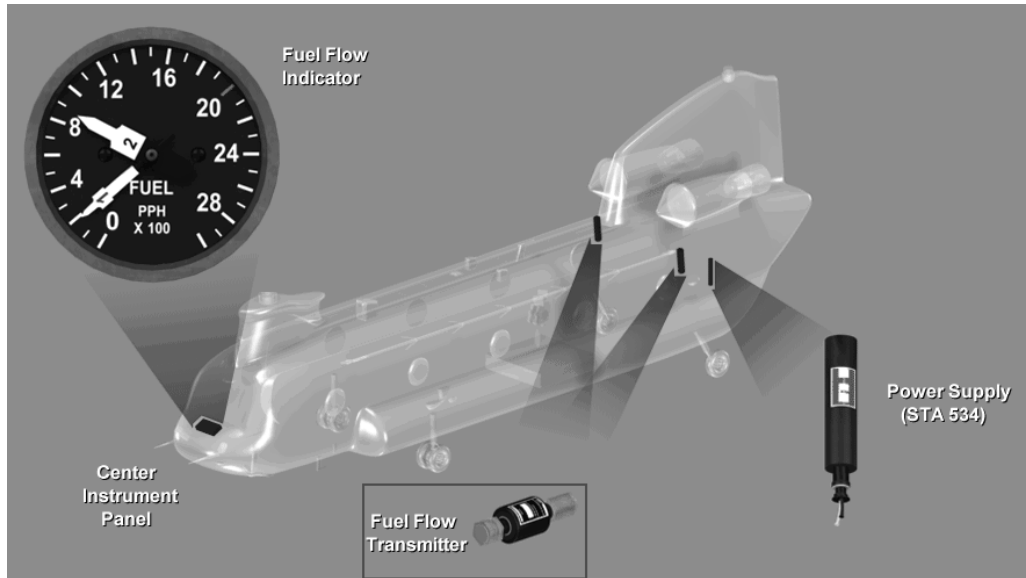

- (7) Fuel flow indicator. Located on the center instrument panel and contains a pointer for each engine.
- (a) Indicates the fuel flow to each engine in pounds per hour.
 - (b) Fuel flow transmitters supply the signal to the indicator.

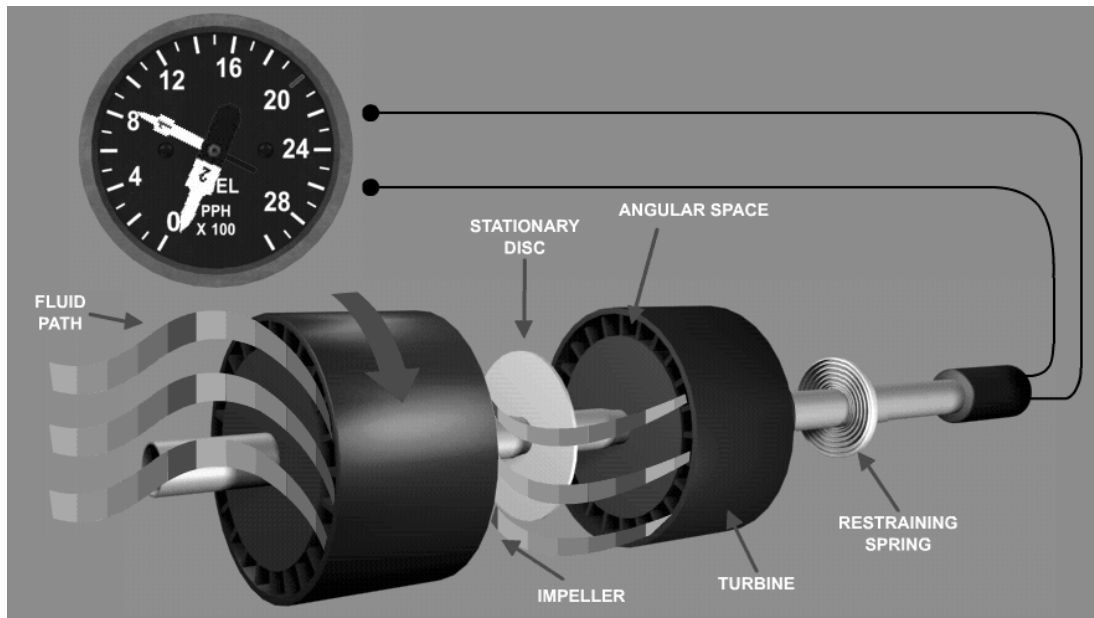

- (c) No.1 and No.2 AC buses through the FUEL FLOW circuit breakers.

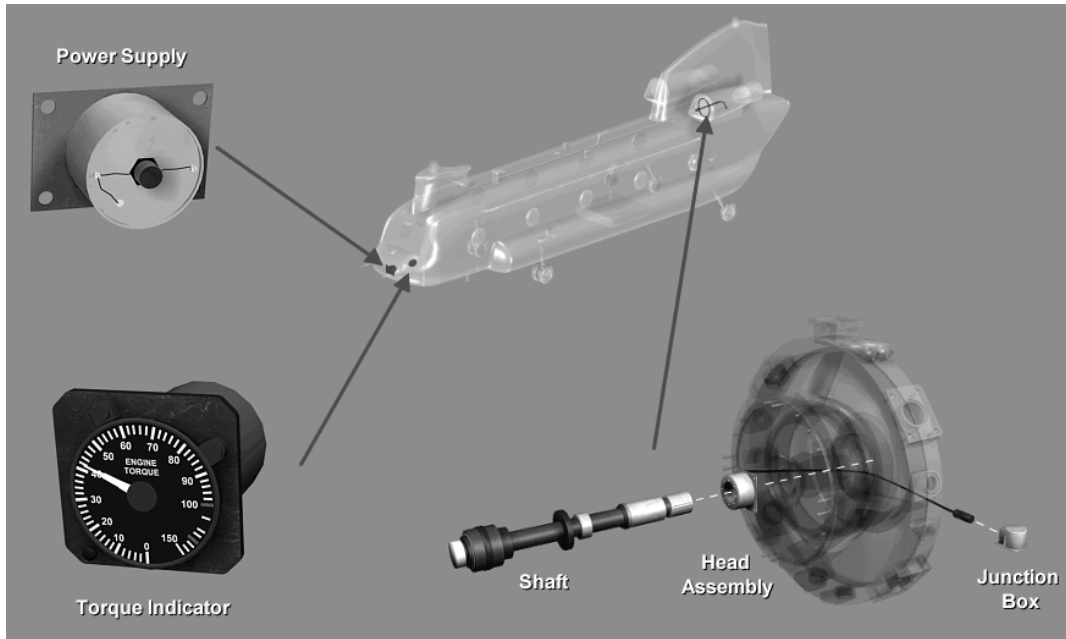

- f. Torque measuring system. Two torque meters are installed on the instrument panel. There is a pointer for each engine and torque is measured in percent.
- (1) Engine mounted components.
 - (a) A sleeve is welded to the power output shaft.
 - (b) The non-rotating head assembly fits around the sleeve.
 - (c) Junction box is mounted to the right side of the inlet housing.
 - (2) Torque limits.
 - (a) Dual engine 100%.
 - (b) Single engine 123%.

NOTE: Refer to a current operator's manual for torque limitations.

Pg: 5-2-2

- (3) Electrical power.
 - (a) No.1 and No.2 AC buses through the ENGINE TORQUE circuit breakers.
 - (b) No.1 and No.2 DC buses through the ENGINE TORQUE circuit breakers.

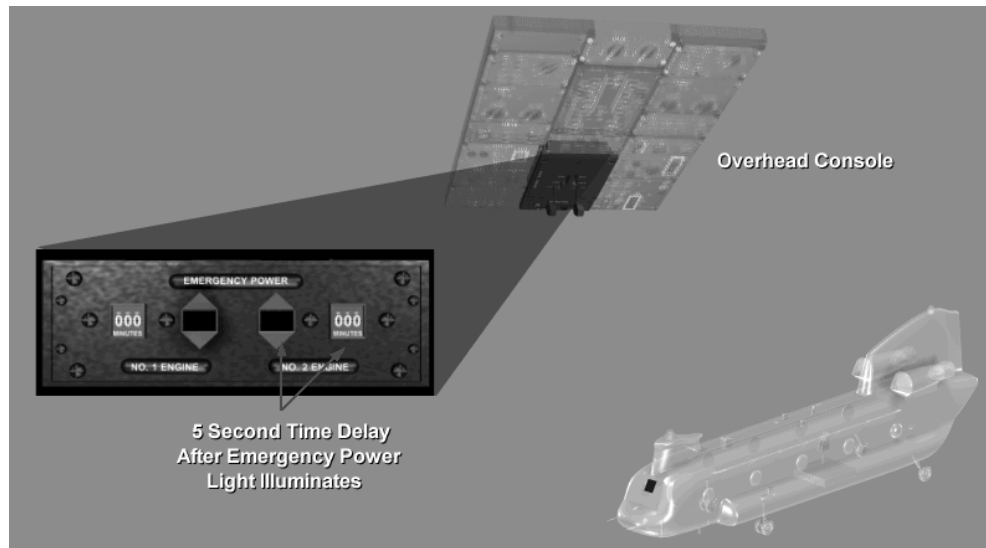

- g. Emergency power system.
 - (1) To be used **only during actual emergency conditions**.
 - (2) After **30** minutes of emergency power time has accumulated, the engine must be inspected.
 - (3) A -13 entry is required each time emergency power is used.
 - (4) The engine will be in emergency power range anytime the PTIT is at or above 890°C.

OPERATOR'S MANUAL CAUTION: To prevent damage, monitor torque and the PTIT indicators when operating with emergency power. Failure to observe these indicators could result in serious damage to the drive train and engines. **Pg:**

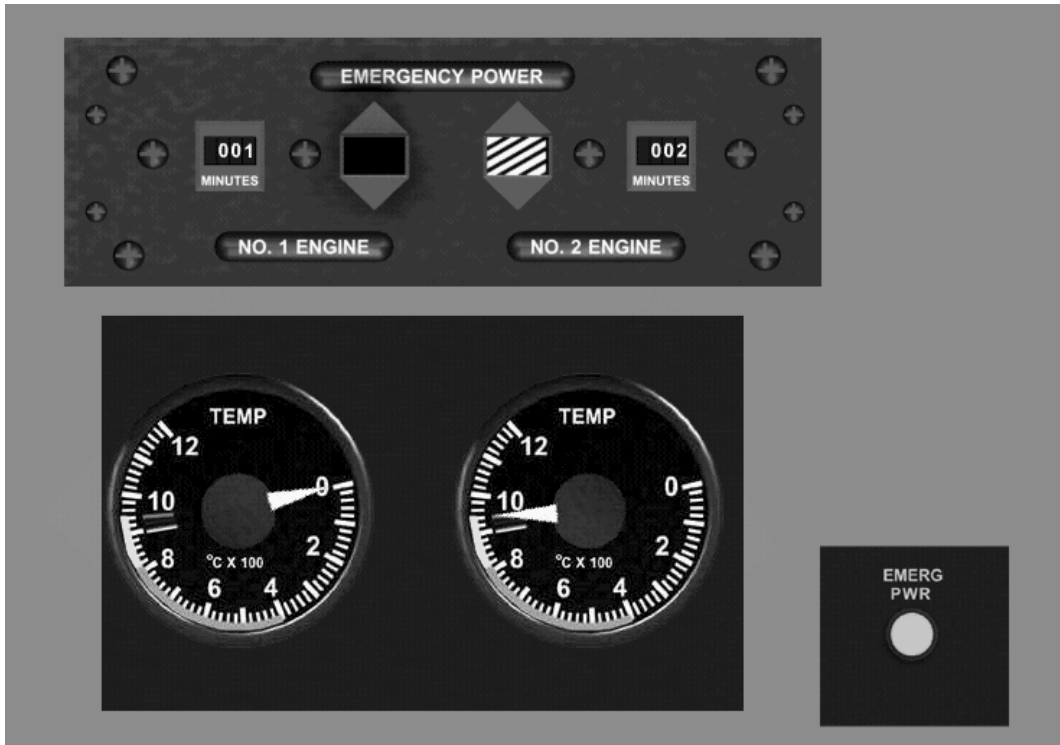

- (5) EMERG PWR lights. When fuel flow increase to the point where **PTIT is 890° to 910°C**, the EMERG PWR lights will illuminate on the copilot and pilot instrument consoles.
- (6) Emergency power panel. Is located on the overhead switch panel and consist of an emergency power indicator (flag) and a digital timer for each engine.
 - (a) Flag.
 - 1) Alternating black and white stripes are displayed when the PTIT has been above 890° C to 910° C for more than five seconds.
 - 2) The flag is reset by a switch in the nose compartment.
 - 3) The engine records will be updated.
 - (b) Timer.
 - 1) Activated 5 seconds after the flag trips.
 - 2) Indicates the **minutes** that emergency power has been in use.
 - 3) The timer cannot be reset.

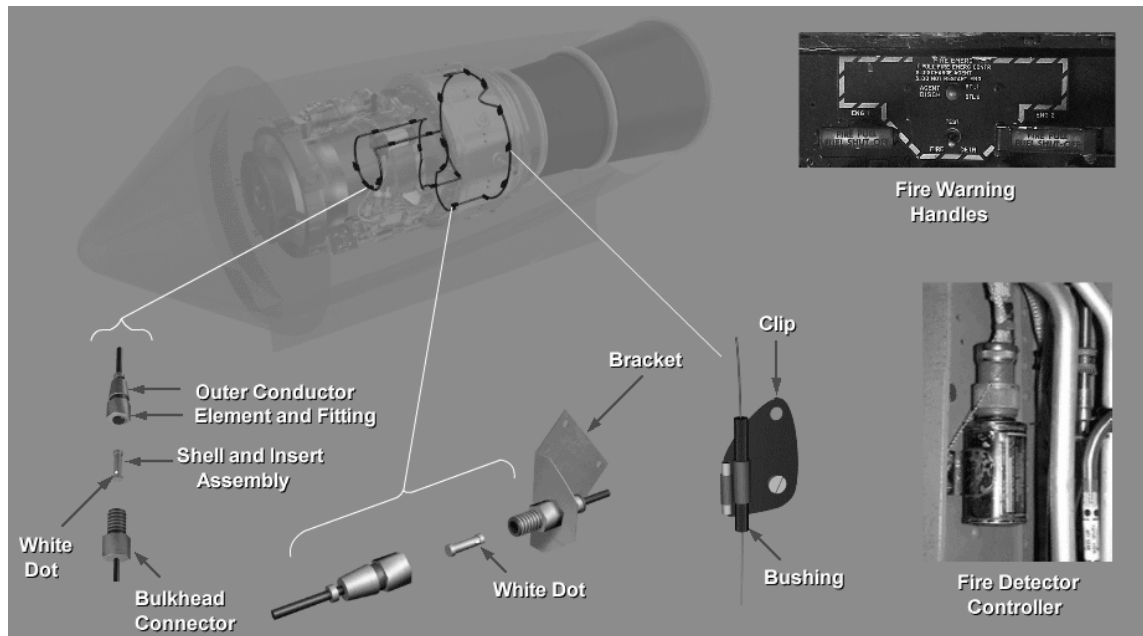

- h. Engine fire detection system. The engine fire detection system is designed to detect fires in the **engine compartment only**.
- (1) The detection element consists of three loops mounted around the outside of each engine.
 - (2) Warning lights.
 - (a) Located in the FIRE PULL handles.
 - (b) Indicates the presence of fire.
 - (3) FIRE DETR switch. A two-position switch labeled FIRE DETR and TEST.
 - (a) Checks the continuity of the entire circuit.
 - (b) The lights should illuminate when the switch is placed to the TEST position.
 - (4) Malfunctions. False indications can be caused by: Moisture in the element or chaffing of the element.
 - (5) Electrical power is through the NO.1 and NO.2, AC buses through the FIRE DET and FIRE EXT circuit breakers.

- i. Engine fire extinguishing system. Allows the pilot to extinguish a fire in either engine **compartment**.



- (1) Extinguishing agent containers.
- (a) The containers are located on the overhead structure at stations 482 and 502.
 - (b) The agent – MONOBROMOTRIFLUOROMETHANE – (CBrF_3 or CF_3BR) is stored under pressure by nitrogen.
 - (c) There are two electrically activated discharge valves per container.
 - (d) Agent can be directed to **either** engine.

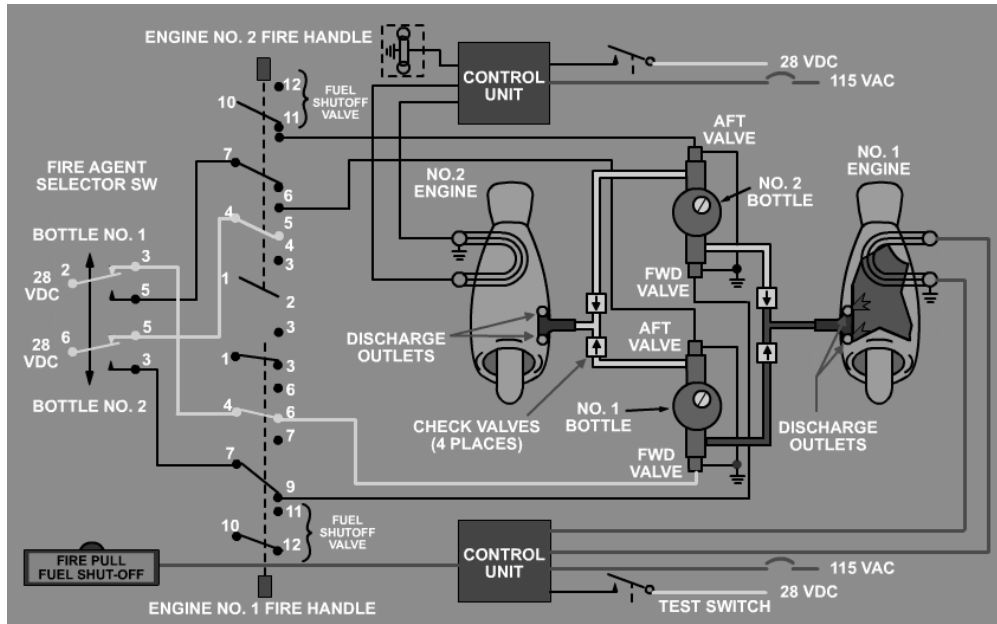

(e) Inspections.

- 1) Electrical connections.
- 2) Pressures. Refer to the chart in CHAP.2 or CL.
- 3) Containers must be weighed within 12 months. Check the log book.

(2) FIRE PULL handles.

- (a) Located on the top center section of the center instrument panel.
- (b) The handle, when pulled, **selects the engine** to receive the agent. If both handles are pulled, the agent will go to both engines.
- (c) FIRE PULL handles, when pulled, arms the AGENT DISCH switch.
 - 1) The AGENT DISCH switch selects the bottle to be used.
 - 2) A three position switch labeled: BTL 1, neutral, and BTL 2.





- (d) Each FIRE PULL handle, when pulled, closes that engines' fuel shutoff valve.

CAUTION: If there is a fire in both engine compartments, do not pull both FIRE PULL handles simultaneously. Extinguish fire in one compartment only as described below. Leave the FIRE PULL handle out after fire has been extinguished. Proceed in a like manner to extinguish fire in the other engine compartment.

WARNING: If the FIRE PULL handle warning lights are covered by the NVG filters during daylight operation, illumination of the fire warning lights may not be apparent in the event of an engine fire. Do not operate the aircraft with the NVG filters covering or obscuring the fire warning lights unless night vision goggles are being used.

NOTE: **Do not push the handle back in after a fire is extinguished!** If handles are pushed back in, fuel will be allowed to flow back to the hot engine possibly resulting in another fire.

- (3) Electrical power, essential bus through the FIRE EXT circuit breakers.

OPERATOR'S MANUAL CAUTION: If there is a fire in both engine compartments, **do not pull both FIRE PULL handles simultaneously!**

3. Learning Step/Activity 3—Describe Malfunctions and Emergency Procedures.



NOTE: The instructor will explain the current –10 procedures.

a. EMER ENG SHUTDOWN.

Pg: 9-1-1 Para: 9-1-3

(1) The term **EMER ENG SHUTDOWN** is defined as engine shutdown **without delay**. Engine shutdown in flight is usually not an immediate action unless a fire exists. Before executing an engine shutdown, identify the affected engine by checking indications of torque, RRPM, N1, PTIT, engine oil pressure and ENG FAIL Caution.

CAUTION: When in-flight shutdown of a malfunctioning engine is anticipated positive identification of the malfunctioning engine must be accomplished to avoid shutting down the wrong engine.

1. **ENG COND** lever — **STOP**.
2. **FIRE PULL** handle — **PULL** (Engine fire only).
3. **AGENT DISCH** switch — **As required**. (Engine fire only)

b. ABORT START.

Pg. 9-1-1. Para: 9-1-3.

The term **ABORT START** is defined as engine shutdown to prevent PTIT from exceeding limits or whenever abnormal operation is indicated. If high PTIT was indicated, the engine must be monitored to decrease PTIT below 260°_C.

1. **ENG COND** lever — **STOP**.
2. **ENG START** switch — **MTR.** (if high PTIT is indicated).

c. Engine Failures: Indications and procedures.

(1) Dual.

Pg. 9-1-6. Para: 9-1-10.

1. **AUTOROTATE**.

2. **External cargo — Jettison.**
3. **ALT switch — Disengage.**

CAUTION: Jettison external cargo as soon as possible after engine failure. This will help to prevent damage to the helicopter during touchdown and will reduce weight and drag, thereby improving auto-rotational performance.

CAUTION: The helicopter must be maneuvered into the autorotation approach corridor prior to landing to assure a safe outcome of the maneuver.

(2) Single Engine Failure — Low Altitude/Low Airspeed and Cruise.

Continued flight is possible:

1. **Thrust control — Adjust** as necessary to maintain RRPM.
2. **(712 Only) ENGINE BEEP TRIM switch —RPM INCREASE** as required.
3. **External cargo — Jettison** (if required).
4. **ALT switch — Disengage.**
5. Land as soon as practicable.
6. **EMER ENG SHUTDOWN** (when conditions permit).

NOTE: If S/E flight can be maintained, an attempt to restart the inoperative engine may be made if there is no evidence of fire or obvious mechanical damage.

Continued flight is not possible:

Land as soon as possible.

d. Engine restart during flight. Pg: 9-1-17. Para: 9-1-14.

WARNING: Fire detector and extinguishing systems are not provided for the APU. Crewman must monitor APU area for fire.

CAUTION: If abnormal indications are present during the restart, shut down the engine immediately.

1. APU — Start.
2. (712) ENG COND lever (inoperative engine) — STOP.
3. (714A) ENG COND lever (inoperative engine) — STOP, then GND.
4. FIRE PULL handle — In.
5. All FUEL PUMP switches — ON.
6. XFEED switch — As required.
7. Starting engine — Perform.
8. APU — OFF





e. **ENG OIL LOW or ENG CHIP DET.**

Pg: 9-1-20.

Engine Oil — Low Quantity/High Temperature or Low Pressure.

Para: 9-1-29.

A low engine oil quantity condition will be indicated by the lighting of the NO.1 ENG OIL LOW or NO.2 ENG OIL LOW caution light. When either one or both of these caution lights come on, about 2 quarts of usable oil remain in the respective oil tank. If one or both of the caution lights come on, check oil temperature and oil pressure indicators (affected engine) for abnormal indications. If the indication on the oil temperature indicator is high or the indication on the oil pressure indicator exceeds limits, high or low, perform the following:

1. If engine power is required for flight:
Land as soon as possible.
2. If engine power is NOT required for flight:
 - a. EMER ENGINE SHUTDOWN — Affected Engine)
 - b. Land as soon as practicable.

Para: 9-1-30. Engine Chip Detector Caution Light ON.

If either NO. 1 or NO. 2 ENG CHIP DET caution light comes on, perform the following:

1. If engine power is required for flight:
Land as soon as possible.
2. If engine power is NOT required for flight:
 - a. EMER ENGINE SHUTDOWN — (Affected Engine)
 - b. Land as soon as practicable.

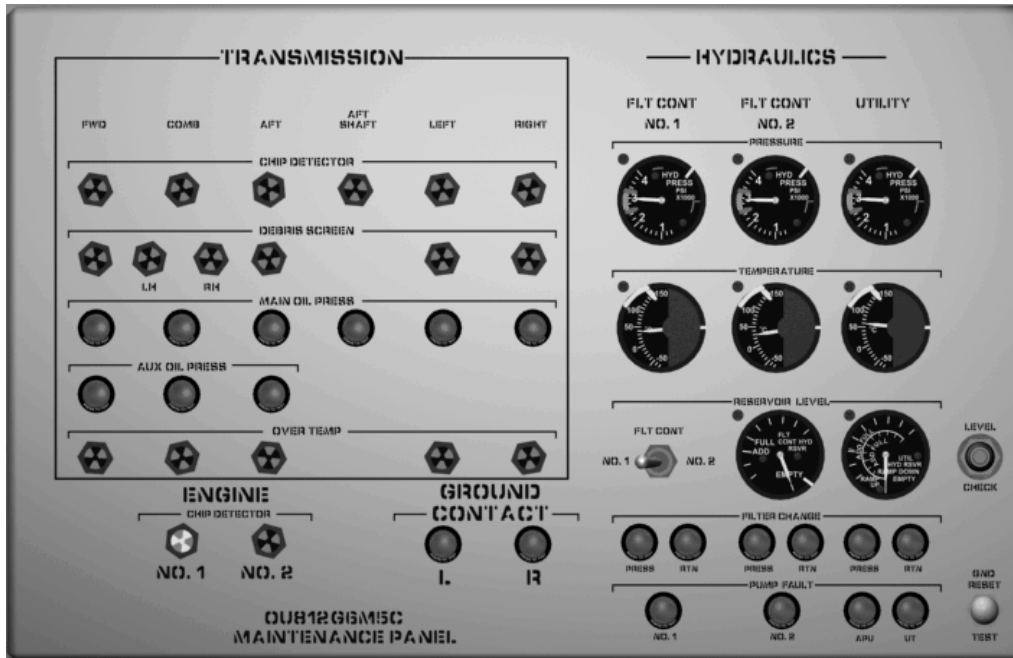

f. Torque Measuring System Malfunctions. Pg: 9-1-22. Para: 9-1-40

Malfunctions in the torque measuring system can appear on the torquemeter as fluctuations, zero torque indication, sluggish movement, indications that are out of phase, or a stationary indication. If this occurs, proceed as follows:

N1 and PTIT indicators — Check.
 N1 and PTITs not matched.

1. LOAD SHARE switch — PTIT.
2. PTIT indicators — Check. PTITs not matched.
 Land as soon as practicable.

N1s and PTITs are matched.

AC and DC Torque and Engine circuit breakers — IN.

g. Engine Hot Start or Residual Fire During Shutdown. Pg: 9-1-22.

ENGINE HOT START. Para: 9-1-42.

A hot start will be detected by a rapid and abnormal rise in PTIT and/or by observing flames and black smoke coming from the engine tail cone. Complete the following on the affected engine.

ABORT START

Para 9-1-43. Residual Fire During Shutdown.

A residual engine fire may occur during shutdown. It is caused by residual fuel igniting in the combustion chamber.

1. **ABORT START.**
2. **FIRE PULL handle (affected engine) — Pull.**

h. Engine Fire - Flight. Pg: 9-1-22

Para: 9-1-45. Engine or Fuselage Fire — Flight.

Visible flames, smoke coming from the engine or the lighting of the respective FIRE PULL handle:

1. **Land as soon as possible.**
2. **Confirm Fire. (Flight Engineer)**
3. **EMER ENG SHUTDOWN (affected engine).**

After landing:

EMER ENG SHUTDOWN.

NOTE: Always refer to a current operator's manual for the current emergency procedure!

Appendix C - Practical Exercises and Solutions

CH-47D POWER PLANT

PRACTICAL EXERCISE PROCEDURES

NOTE: This practical exercise covers the instruction you received in this handout. Completion is optional, but strongly encouraged!

1. What component aids in rapid acceleration of the compressors?
2. How will bleed band popping be indicated?
3. What engine instrument indicates that the engine is operating at a time limited power level?
4. What should be done before adding engine oil if the indicator shows low quantity and the aircraft has been shut down more than 24 hours?
5. If the torque measuring system fails, what instruments should the pilot monitor to keep the output of the engines matched as closely as possible?
6. How much usable oil remains in the engine when the OIL LOW caution light comes on?
7. What indications other than PTIT, will you have when the engine is operating in the emergency power range?
8. What free air temperature requires removal of the engine inlet screen bypass panels?
9. Under what conditions can emergency power be used?
10. What are the indications that an engine has failed?
11. What are 3 of the 5 components of the torque measuring system?
12. The fuel flow divider divides the fuel into _____ and _____ fuel flows.
13. If the ENG CHIP DET caution light comes on, how will the crew determine the location of the metal particles?
14. Pulling the fire pull handle does what two things?

15. When does an N_1 over-speed exist?

16. The engine is operating in the emergency power range when PTIT is above _____ degrees?

CH-47D POWER PLANT

PRACTICAL EXERCISE SOLUTIONS

1. Bleed Band Actuator
2. Fluctuations in torque N_1 speed, PTIT, and noise.
3. PTIT.
4. Run the engine up to operating temperature, shutdown and recheck oil level.
5. N_1 tachometer, and Fuel Flow meter.
6. Two quarts.
7. Flag, light, and timer.
8. At temperatures below 4°C
9. Actual emergencies
10. Torque split, drop in rotor rpm, N_1 decreases below 60%.
11. Power Output Shaft, Head Assembly, Junction Box, Power Supply, Torque Indicator.
12. Primary and Secondary Fuel Flows
13. Maintenance panel.
14. Closes the Engine fuel shutoff valves, and Arms the Agent Discharge switch
15. 107% is exceeded.
16. 890°C PTIT.

