

“IMPOSSIBLE TO RESIST”

THE DEVELOPMENT OF ROTORCRAFT FLY-BY-WIRE TECHNOLOGY

L. Rus Stiles
Test Pilot

John Mayo
Program Manager, Fly-By-Wire
Sikorsky Aircraft Company

A. Lynn Freisner
Test Pilot, Retired

Kenneth H. Landis
Senior Manager, Flying Qualities

Bruce D. Kothmann
Engineer, Flying Qualities

The Boeing Company

ABSTRACT

The past half century has seen the evolution of rotorcraft flight controls from early mechanical systems to modern redundant hydraulic systems with full-authority digital flight control computers. Despite the recent cancellation of the RAH-66 Comanche program, the future of rotorcraft fly-by-wire technology looks brighter than ever, with fly-by-wire in production or development on the V-22, NH-90, BA-609, UH-60, AH-64, Mi-38, and S-92, among others. Drawing on the personal experiences of two project test pilots and several design engineers, the paper describes the development of the important elements of successful fly-by-wire systems.

INTRODUCTION

As early helicopter designs matured, the speed, maneuverability, and performance capabilities increased, and, consequently, the aircraft became more difficult to fly [1, 2, 3]. The situation was especially acute when flying on instruments with poor visibility, at night or in adverse weather [4, 5]. In 1964, Professor Seckel of Princeton University offered the following assessment of the future direction that rotorcraft flight controls technology might take to address these challenges [14]:

Helicopters, except the smallest, use control boost systems because of the unruly character of the blade feathering moments and vibrations. These boosters are essentially equivalent to the servos required for artificial stability systems. A number of the stability problems of helicopters appear to be quite fundamental in character, defying solution by “natural” means. The need, and some of the means, to fly by wire are thus upon the helicopter designer; and with

improved protection against failures, and better reliability, these systems will surely be used more frequently in the future.

In conclusion, Seckel opined that, for rotorcraft, “the fly-by-wire concept is impossible to resist.”

This paper reviews the decades of technological development that have turned Professor Seckel’s prophesy into the present reality, as shown conceptually in Figure 1.

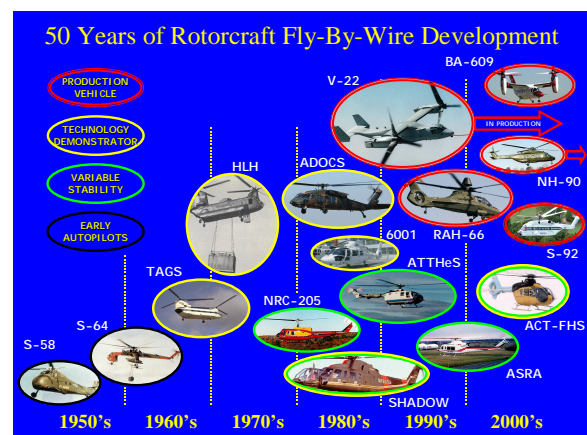

Figure 1. Rotorcraft Fly-by-Wire Time Line.

Presented at the American Helicopter Society 60th Annual Forum, Baltimore, MD, June 8-10, 2004. Copyright © 2004 by the American Helicopter Society International, Inc. All rights reserved.

MECHANICAL DEVICES

The earliest efforts to provide some measure of “artificial” stability relied on cleverly conceived mechanical devices. The ability of the Young-Bell bar and Hiller servo rotor to stabilize the near-hover dynamics of a helicopter by effectively providing lagged rate feedback to cyclic pitch was well understood by 1950 [11]. Perhaps less well known today are the various other devices designed to provide improved stability in forward flight. One novel approach [6] involved installation airfoils as “flow sensors,” generating either force inputs *directly to the swashplate* of an aircraft without hydraulic boost, or displacement inputs to a mechanical adder of an aircraft with boost, as shown in Figure 2. The concept was successfully evaluated on four aircraft, including a Sikorsky H03S-1 (single rotor) and a Piasecki XHJP-1 (tandem rotor), as shown in Figure 3. The limitations of then-current electronic components were revealed when the “simplicity of this method of improving the helicopter’s stability and possible weight savings over a full electronic type of autopilot” were cited as advantages of the scheme. Similar conclusions were reached with a mass-balance (“accelerometer control”) approach [7], as shown in Figure 4, which was evaluated on a Bell Model 47: “many more helicopter missions become possible which might otherwise require the weight, expense, and complication of an autopilot.”

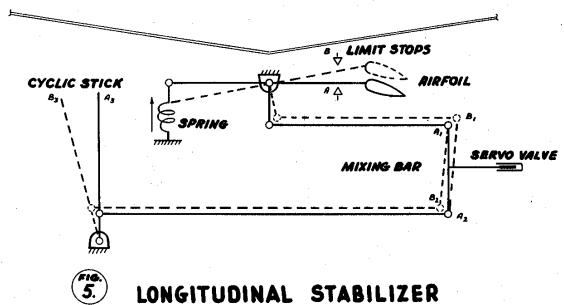

Figure 2. Longitudinal Stabilizer Using External Airfoil Movement as Serial Input to the Hydraulic Boost, from [6].



Figure 3. Longitudinal Stabilizer Installed on the Piasecki XHJP-1, from [6]. Airfoil Pitch Change Actuation Mechanism Controls Trim Speed.

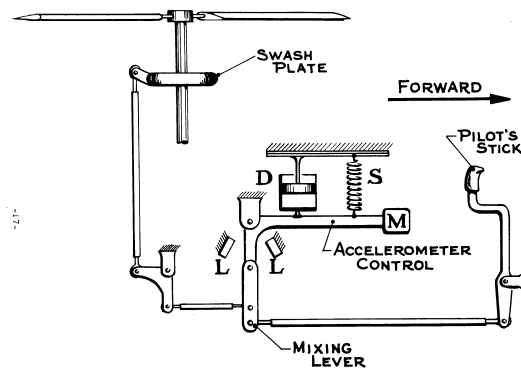

FIG.3. SCHEMATIC OF ACCELEROMETER CONTROL

Figure 4. Schematic of the Accelerometer Control, from [7].

Application of mechanical devices was not limited to improving stability, but also included efforts to improve control response. For example, “mechanical quickeners” were used at Bell [12] to reduce the “lead time” in roll rate response, giving the teetering rotor of the Bell H-13 a roll bandwidth similar to that of the Lockheed rigid rotor, as shown in Figures 5 and 6. In the modern fly-by-wire context, this corresponds to using a (weightless) first-order lead filter to achieve an increase in ADS-33 command bandwidth. (As an aside, ADS-33 relies on several of the findings of [12], notably in supporting the maximum angular rate requirements [13].)

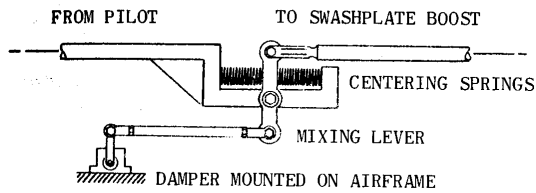

Figure 5. Mechanical “Quickener” (Equivalent of First-Order Lead Filter) from [12].

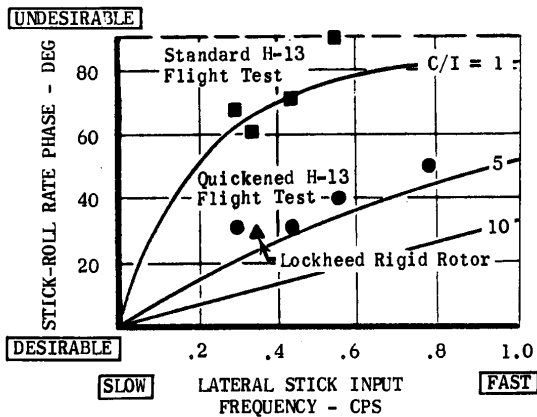

Figure 6. Effect of Mechanical “Quickener” on Phase of Roll-Rate Response (ADS-33 Bandwidth Corresponds to Phase = 45°) from [12].

Despite their widespread and successful use in the early stages of rotorcraft development, mechanical devices are necessarily limited in the number and nature of feedbacks and feed-forwards which can be devised. Nevertheless, important and lasting insights were obtained through development of these devices, including an appreciation of the challenge of allowing the devices to work at an arbitrary trim condition, but with limited authority.

EARLY ELECTRONIC AUTOPILOTS

Initial attempts at electromechanical stability augmentation of helicopters were adaptations of fixed wing autopilots. A Piasecki HUP-1 flew during November of 1950, with an adaptation of the Sperry A-12 autopilot. Sikorsky Aircraft pursued an electronic solution as early as 1952, with the first electronic stability system installed in an S-56, providing gyro rate and attitude feedback to improve gust response and controllability. By 1957, Sikorsky, with 200 aircraft in the field and approximately 30,000 flight hours of experience with electronic automatic stabilization equipment (ASE), proclaimed

[8]: “the state of this art of utilizing electronics in helicopters has outgrown its infancy and is well advanced...ASE is definitely ‘on the shelf’—available to all military customers and very shortly to commercial operators.”

Similar electronic autopilot development and optimization efforts were underway at this time at Kaman [9] and Vertol [10].

The next generation of electronic pilot aids was in the form of hover couplers. In 1960, a system was installed in the S-58 (see Figure 7) that provided limited authority, hands-off hover capability using a Doppler radar and radar altimeter to reference velocity and height. The pilot was expected to allow the system to hover without intervention, although controls were provided to bias the signals. This allowed the pilot to correct for errors in the velocity reference – often because the system was used over water and the Doppler could not distinguish between velocity due to current and absolute velocity (this has since been corrected using global positioning system and inertial reference data). The hover coupler later evolved into automatic approach couplers, which allowed a helicopter operating over water (away from uneven terrain and obstacles) to transition from cruise altitude and speed to hover without pilot intervention. Approach/Hover couplers are now available in virtually every large production helicopter.



Figure 7. S-58 – First Hover Coupler.

A unique implementation of the hover coupler in a Sikorsky product was the incorporation of a remote operator’s station in the CH-54 Skycrane. A multi-axis controller was provided in a small cockpit, aft of the crew station, facing aft towards the external load (see Figure 8). An operator could control the position of the aircraft by making inputs through the

controller, which was electrically connected to input a bias into the autopilot. When the controller was released, the autopilot returned to hover hold. Fore/aft/left/right and yaw control were provided. This controller was an early application of the unique trim stick (see below) found in the RAH-66 Comanche.



Figure 8. CH-54 Skycrane Remote Operator's Station.

The hover unique-trim stick approach was also provided in the MH-53J "Pave Low" helicopter. In this application, the stick was installed in a sidearm controller position and provided limited authority control of pitch and roll while the aircraft was in a coupled hover. (See Figure 9)



Figure 9. MH-53 PAVE LOW III Cockpit (Sidearm Controller at Lower Left)

This allowed the pilot to "fly through" the coupler to reposition the helicopter for precise positioning over

a survivor, and move to a precise landing point. Later applications would recognize the importance to the pilot of this ability to apply corrective inputs to the coupler without disengaging it.

AUTHORITY LIMITS

During the 1950s and 1960s, full-time electronic control augmentation and stabilization came to be very commonly used. Nevertheless, failures were not uncommon, and the ability of the pilot to retain control of the aircraft following a failure was a primary design objective.

Two competing architectures emerged [5]: series systems, in which the pilot and SAS inputs were added mechanically to generate the input to the hydraulic boost; and parallel systems, in which the SAS inputs were added to the integral of the stick force to generate a command to a separate servo, which drove the stick position. For the pilot, the SAS inputs are totally transparent in the series system, but totally visible in the parallel system. As a result, the parallel system was found to be more easily recoverable following failures, and authorities of 50-percent of full travel or more were implemented [9]. For the series system, failure recovery dictated a much smaller authority, typically about 10-percent of full travel. This was a potentially significant limitation, because actuator saturation causes the aircraft to "go open loop," changing the stability characteristics in mid-maneuver. However, the series system offered notable advantages in other areas: trim was more easily managed with properly designed switches and springs; and power and weight were lower than for parallel systems.

Eventually, the series-style systems were enhanced by the addition of variable-length control rods, which allowed the SAS to alter aircraft trim characteristics—for example, the Pitch Bias Actuator (PBA) on the Sikorsky S-76 provides apparent static speed stability [35]. These rods were driven by electrical or other actuators with a relatively slow maximum rate of movement. Under these schemes, the SAS had small authority at high frequency but large (or full) authority at low frequency. As we will see, this "frequency splitting" of SAS authority limits would be a key concept in future fly-by-wire systems.

For modern limited-authority SAS implementations, saturation of the feedback remains a significant design challenge. Large amplitude or rapid rate maneuvers occasionally saturate the augmentation, resulting in degraded stability and controllability. For example, loss of maneuver stability, or "dig in,"

during aggressive pull-ups is a common problem arising from SAS saturation. As a result, with a conventional SAS, it is occasionally necessary to reduce flight envelopes after the first in-flight failure of a redundant system.

DIGITAL ADVANTAGES

In 1945, the ENIAC computer, consisting of tens of thousands of vacuum tubes, resistors and relays, filled a room of some 1500 square feet. Within a decade, the potential to replace much of this hardware with the transistor would be known, and by 1970, the concept of a digital microcomputer would be an imminent reality. These developments had a profound impact on the world of fly-by-wire flight controls, offering improvements in the weight, cost, reliability, as well as accuracy, ease of configuration change, and ease of maintenance. The digital computer also presented a totally new challenge, as the primary burden of verification shifted from hardware to software [30].

It is interesting to note that much of the current fleet of stability augmentation systems involves limited authority analog systems. Recent research [31, 32] has shown that significant improvements in handling qualities can be obtained by employing modern control laws in a digital computer within these limited-authority architectures. After more than 40 years of experience with an analog system, a digital AFCS is currently being developed for the CH-47 Chinook.

RELIABILITY THROUGH REDUNDANCY

In the late 1960's, the electronic SAS was nearly ubiquitous in rotorcraft of all kinds, with the more sophisticated "autopilot" functions discussed above also frequently used. But the full potential for improvements in handling qualities, and more importantly, the notable savings in weight, could only be realized by a full-authority fly-by-wire primary flight control system. Technological advances had reduced the cost, size, weight, power, and cooling requirements of digital computers and inertial sensors, so that the primary remaining barrier to acceptance was reliability, which required redundancy.

Pilots remained quite wary of electrical components in control systems due to their relatively high failure rates. Electrical elements such as trim motors, switches, etc., failed much more frequently than hydromechanical components. See Figure 10 for a histogram of causes of electronic SAS failures during

one year of Sikorsky experience. A comment overheard from a pilot in the 1970's was, "Fly-by-wire is quite acceptable to me, provided the wire is routed through the center of the control rods."

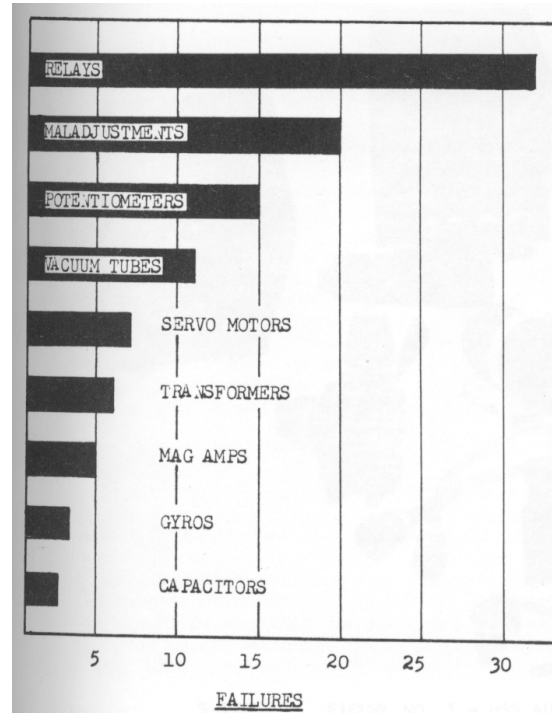

Figure 10. Causes of Failures in Automatic Stabilization Equipment on Sikorsky Aircraft in 1956, from [8].

Pilots certainly recognized that the benefits to be realized from fly-by-wire were enormous: stability and control system fidelity and response improvements, control mixing flexibility, reduced combat vulnerability, as well as better performance due to reduced airframe weight. But the feasibility and dependability had to be safely demonstrated. The thought of a maximum control rate full authority hardover was terrifying.

It was at this time that the U.S. Army Air Mobility Research and Development Laboratory (AMRDL) and the Canadian Department of Industry, Trade and Commerce jointly sponsored a research program known as the Tactical Aircraft Guidance System, or TAGS [15]. The objective of the program was to develop and demonstrate digital fly-by-wire flight controls on a helicopter, including advanced control laws and the redundancy management required for fault-tolerant operation.

Two CH-47B tandem-rotor helicopters were used as test vehicles for development of the TAGS concept. The pilot stations were modified to permit TAGS evaluation by one pilot and conventional control system monitoring by a second pilot (the “safety pilot”). See Figure 11. The TAGS pilot inputs were made through a 3-axis sidarm controller and a vertical velocity (collective) lever.

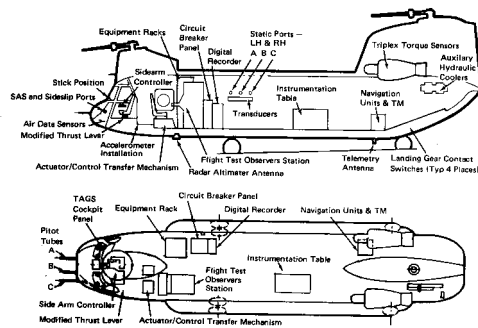

Figure 11. TAGS Aircraft (Modified CH-47B)

The control responses were essentially pure and uncoupled and were designed as follows:

- Longitudinal: Longitudinal ground speed command to 30 knots blending linearly to airspeed command above 110 knots.
- Lateral: Lateral speed command throughout the envelope; ground track angle to 40 knots forward speed blending linearly to air mass referenced steady heading sideslip above 80 knots.
- Directional (Grip Twist): Turn rate command at all speeds—flat turns in hover and coordinated turns in forward flight.. (This paradigm avoids swapping lateral-directional control axes between low and high speeds, as with conventional controls, and also tests the axiom that humans are very adaptable creatures.)
- Vertical: Vertical velocity command.

Each axis included integral feedback and automatic trim, so that the pilots control position depended only on the flight condition, not the swashplate position (more on managing trim below).

The method used to provide suitable reversion to conventional control was to backdrive the conventional controls through electrohydraulic clutches. To avoid transients during reversion, the conventional SAS, which was effected through actuators “downstream” of the pilot stick, remained active, but the SAS commands were subtracted from

the TAGS commands, effectively cancelling the SAS effect on the aircraft response.

Initial flight testing employed only a simplex digital system with the intent of verifying system response and stability. Mechanical control stops, included at this stage to ensure recoverability, were sized using SAS failure flight test results as a guide. The system demonstrated excellent characteristics, including excellent decoupling of the off-axis response.

The crucial final stage of the program was evaluation of the full-authority triplex system, which provided automatic isolation and identification of, as well as continued operation after, any single failure. Each channel in the system had a dedicated sensor of each functional type, with in-line and cross-channel monitoring to ensure validity. TAGS made many important contributions to the development of redundancy management [16] (many of which were implemented on the RAH-66 Comanche [33]), including computer synchronization, individual unit self-test, majority voting logic, and median value selection (which results in smaller failure transients than averaging). Nevertheless, because the system was not subjected to extensive failure modes analysis or rigorous system validation testing, it was necessary to protect against generic hardware and software errors by including an automatic disengage capability. An electronic actuator rate monitor system was adapted with a specific rate amplitude curve (derived with an assumed 1-second recovery delay) for each axis. The system would revert to convention control if any curve were exceeded. This limitation allowed full-envelope operation in trim and a very useful maneuver envelope. The TAGS was ultimately evaluated over a substantial portion of the CH-47 envelope.

Among other important conclusions [15], the TAGS test program demonstrated that digitally computed full-authority fly-by-wire was practically feasible in the rotorcraft operational environment and that software voting and switching were viable techniques for redundancy management.

GENUINE FLY-BY-WIRE

Although the TAGS demonstrated that digitally computed full-authority fly-by-wire was practically feasible, the wires were only from the cockpit to the lower control boost actuators. Furthermore, the retention of mechanical controls and the possibility of reversion to a safety pilot were obviously not production-worthy features of the system.

The XCH-62 Heavy Lift Helicopter (HLH) demonstrator program was conducted between June 1971 and October 1974 [24, 25, 27, 26]. A Boeing model 347 helicopter was modified to become the world's first genuine fly-by-wire helicopter. The normal mechanical controls were disconnected, with primary flight control implemented through an analog Direct Electrical Linkage System (DELS), which provided swashplate control mixing, actuator servo loops, an interface to the Automatic Flight Control System (AFCS), as well as monitoring and built-in-test (BIT) functions. The digital AFCS was a triplex architecture, utilizing redundancy management similar to the TAGS. The interface between the AFCS and the DELS was the electronic analog of the mechanical SAS limits discussed earlier. That is, the AFCS signal was passed through a frequency splitter, with a limited authority at high frequency and a rate limit at low frequency. The division of the flight controls into a simpler PFCS for flight-critical tasks and an AFCS for mission-critical tasks became a cornerstone of rotorcraft fly-by-wire for the next several decades.

The program further demonstrated the novel possibilities of fly-by-wire by implementing an aft facing external "Load Controlling Crewman" (LCC) station that integrated an earth referenced position laser sensor feedback into a 4-axis "finger controller." This feedback provided outstanding hover positioning and station keeping performance, including active suppression of sling-load pendulum modes. The system was so robust that even the design engineers were able to position the aircraft with only a few inches of error! See Figure 12.



Figure 12. HLH Demonstrator Was So Easy to Fly That Even Design Engineers Could Do It!

The HLH demonstrator incorporated selectable modes (discussed below) to provide Level-1 handling

qualities for a variety of mission tasks. The HLH demonstrator was flown throughout the 347 flight envelope accumulating more than 300 hours. See Figure 13.



Figure 13. HLH Demonstrator Logged More Than 300 Hours of Flight Time (the Prototype Model 347 Logged a Total of 1000 Flight Hours).

MATURITY MATTERS

By the mid-1970's the advantages of fly-by-wire for rotorcraft were becoming increasingly clear [30]:

- Reduced Cost and Weight
- Improved Reliability
- Improved Survivability
- Elimination of Mechanical Anomalies
- Relief of Spatial Constraints
- Improved Mission Performance

Nevertheless, fly-by-wire systems were not sufficiently mature to be proposed by either of the final (Boeing and Sikorsky) UTTAS efforts. Sikorsky's winning UH-60 did use digital fly-by-wire to control the stabilator [34]. Similar work in development of a fly-by-wire elevator was underway at Bell at this time [37]. Boeing's UTTAS effort included an optional alternative proposal to replace the dual-redundant mechanical system of the YUH-61 with a fly-by-wire system, for an estimated weight savings of 83 pounds. Other details and a summary of the state-of-the-art at the time were described in [30].

But another decade of research and development would be required before rotorcraft fly-by-wire would enter the production era.

CONTROL LAW DEVELOPMENTS

The TAGS demonstrated several key concepts in the adoption of the model-following control law paradigm. One of the primary challenges presented to the pilot by the model-following concept, namely that pilot “corrections” must be made through the command model. As described in [15], “TAGS has stick steering, but the directional-moment control is not directly available. Improvements in turn coordination can only be made by modulation of the lateral velocity command.” This is a new way of flying, to which the pilot must adapt.

Another key TAGS technology, which would be developed further over the following decades, was the use of integral feedback for the management of trim. In this way, the system insures high bandwidth command with a stable trim hold capability. For example, in TAGS, integral feedback of vertical velocity not only provided altitude hold, but also set the trim collective pitch.

Because TAGS provided a single command response type in each axis throughout the flight envelope (e.g., velocity command in pitch and roll), it did not fully confront the challenge of control law moding, in which the command response type and level of augmentation change with flight condition and, at the discretion of the pilot, with the usable cue environment. Moding was emerging as a key capability as understanding of rotorcraft handling qualities increased (see below), and selectable modes were incorporated on the HLH demonstrator.

Major advances in model-following technology for rotorcraft were made in the 1980’s, as Boeing, under a US Army contract, designed and flight tested the Advanced Digital/Optical Control System (ADOCS). Providing a considerable boost to the industry-wide confidence in digital electronic primary flight controls, ADOCS logged over 500 hours of flight testing with a digital “fly-by-light” system installed on a modified UH-60A Black Hawk, shown in Figure 14. This demonstrator aircraft, which retained mechanical backup in a fashion similar to the TAGS, provided an excellent testbed for development of explicit model following control laws. Another major advancement achieved in ADOCS was the development of multi-mode control laws, seamlessly integrated with the unique-trim sidearm controller.



Figure 14. The UH-60 Blackhawk Was Selected as the Platform for the ADOCS Program.

The advances in model-following achieved in TAGS and ADOCS have direct lineage to both the V-22 Osprey and RAH-66 Comanche, both of which are discussed further below. Many additional aspects of control law design for digital fly-by-wire systems are given in [17].

FLY-BY-WIRE & PILOT INCEPTORS

Fly-by-wire designs provide the possibility for incorporation of a variety of pilot inceptor configurations—virtually any interface imaginable.

A fly-by-wire system could appear to be completely conventional to the pilot, with proportional control sticks and an artificial feel system that virtually replicates the mechanical control system. Indeed, such an implementation would retain many desirable handling qualities features, such as readily apparent static speed stability, tactile cueing to the pilot with respect to impending control-authority limits, and improvements in the pilot’s ability to manage trim.

However, the sidearm controller, which can range from a non-moving force sensor (as on the original prototype F-16), to a compliant controller with mechanical spring centering, provides the most weight efficient acceptable solution for the helicopter cockpit. With the clear potential for significant weight savings, the sidearm controller became the center of much research attention, as little was known about how to make these devices work as the primary controller in rotorcraft. The issues to be resolved included the following:

- Controller active mass
- Controller size and shape
- Controller compliance (force versus displacement) and displacement range (if any)

- Number and choice of axes, for example:
 - “4+0” = 4-axis sidearm (pitch/roll/yaw/heave)
 - “3+1” = 3-axis sidearm (pitch/roll/yaw) with displacement collective
 - “2+1+1” = 2-axis sidearm (pitch/roll) with displacement collective and pedals
- Control law treatment of sidearm inputs

The original TAGS cockpit control design was a rather large displacement, large active mass 4-axis sidearm controller. See Figure 15. The large displacement in the longitudinal and vertical axes, combined with the large active mass, caused serious anthropomorphic command coupling. The controls were reconfigured to a 3-axis sidearm control and vertical control (collective) lever. Although that configuration was acceptable for flight evaluation, the lesson learned was that sidearm control active mass and displacements must be sized within acceptable limits. Nevertheless, the TAGS also showed the potential for more precise control, as the electronic inceptors have fewer problems with friction and deadbands than mechanical controllers.



Figure 15. Massive TAGS Sidearm Controller.

One fundamental challenge presented by the small-displacement sidearm controller is striking a balance between sensitivity for small inputs and achieving an acceptable maximum rate at full authority. Inputs from the LCC controller, shown in Figure 16, on the HLH were passed to a static nonlinear shaping function, shown in Figure 17. The “beep, creep, and leap” paradigm produced a 2-inch position reference increments for the very smallest inputs, a low

sensitivity for small inputs, and an increasing larger response up to full deflection.

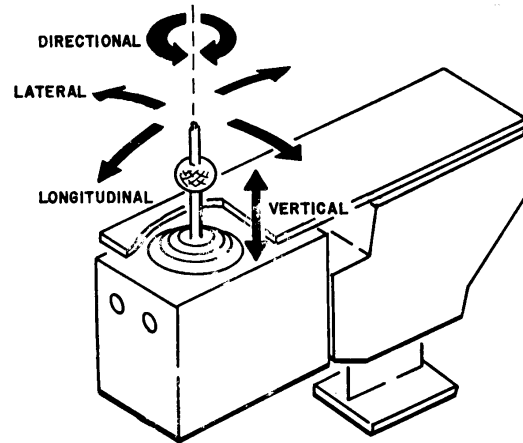

Figure 16. The HLH Load-Controlling Crewman (LCC) Controller.

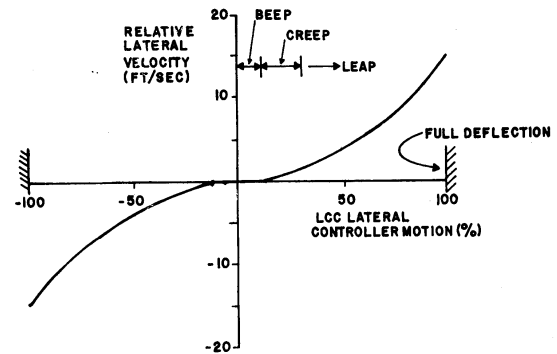

Figure 17. “Beep, Creep & Leap” Paradigm on the HLH LCC Controller.

Sikorsky Aircraft partnered with NRC in 1979 [18], employing the variable-stability Bell 205 (more details below) to conduct research directed primarily at defining the configuration of a fly-by-wire inceptor that would be incorporated into a future small aircraft for the US Army (later to be known as the RAH-66 Comanche). Control laws provided options for varying levels of stability, ranging from direct drive to attitude command/attitude hold. A number of experiments were conducted, primarily to define the controller configuration.

Sikorsky Aircraft continued this research, first with an S-76 modified in a manner similar to the Canadian Bell 205, then later to the unique SHADOW research helicopter [53]. The SHADOW, shown in Figure 18, incorporated a full cockpit in front of the

conventional cockpit. The SHADOW cockpit was reconfigurable to include a wide variety of sidearm configurations. In addition, the SHADOW aircraft incorporated selectable control laws. In the baseline mode, the system provided rate command/attitude hold functionality. A selectable mode with additional augmentation provided attitude command/velocity hold. In this mode, the controller provided essentially command steering. The SHADOW aircraft was also equipped with a glass cockpit and helmet display. This recognized the importance of evaluating the control system as part of the integrated crew station.



Figure 18. SHADOW Research Aircraft.

Boeing’s work with sidearm controllers continued in the 1980’s on ADOCS. The initial simulation portion of the ADOCS study examined an exhaustive matrix of sidearm controller configurations (see Figure 19), control law command response types, and display systems [40]. As a result of this work, the rigid sidearm was discarded prior to the flight test demonstration program, which went on to confirm the simulation finding that the 3+1 configuration, with a limited displacement collective (ADOCS used just 4-inches of collective range) was the overall best configuration for the mission tasks of a light scout/attack helicopter.



Figure 19. Sidearm Controllers Evaluated as Part of the ADOCS program.

TRIM MANAGEMENT

One particularly challenging technical hurdle on the path to production fly-by-wire systems was the problem of managing trim—the steady control required to achieve a given flight condition. With a conventional controller, the most robust scheme, at least in the longitudinal axis, is for the pilot inceptor to carry trim. But if the aircraft does not exhibit positive static stability, some additional “trim storage” will be necessary. And a unique-trim sidearm mandates, by definition, some form of electronic trim storage. The typical choice is an integrator node, with inputs coming from feedback, for example of the attitude error in an attitude-hold system. Recalling that the low-frequency path from the AFCS requires a rate limit for failure recoverability, it becomes clear that the primary difficulties with this implementation will occur with large and rapid changes in the required trim state. Another significant challenge is robustly resetting trim in a single flight-control computer following a power interruption, to avoid a cross-channel actuator “force fight.”

WHAT DO PILOTS WANT?

In parallel with the developments of experimental fly-by-wire aircraft, inceptors, and control law design, important advances were also made in understanding rotorcraft handling qualities. From the perspective of the control law designers, a simplistic view of the issue essentially became: given the capability to achieve model following, what model should the aircraft follow? This question could not be answered in the earliest days of fly-by-wire aircraft; more research was required.

Throughout the history of rotorcraft fly-by-wire, variable-stability aircraft (also known as in-flight simulators) have been a key asset in the development of rotorcraft handling qualities requirements. The National Research Council (NRC) of Canada pioneered this concept for advanced helicopter flight controls in the early 1960’s. In the 1970’s, a Bell Model 205A-1 helicopter was modified with a (single-channel) full authority fly-by-wire station in one seat (see Figure 20). The aircraft retained full mechanical controls for the safety pilot, in a similar fashion to the TAGS aircraft. The presence of the safety pilot allows for rapid prototyping of new hardware and software in the flight environment.



Figure 20. NRC Bell 205 Fly-By-Wire Research Vehicle.

The TAGS aircraft, a modified CH-47B, became a key asset in the NASA Langley Vertical Approach and Landing Technology (VALT) program of the late 1970's [41]. In 1979, the aircraft was transferred to Ames Research Center for use as an in-flight simulator [42].

The DLR Institute for Flight Mechanics in Germany developed in-flight simulation with a modified BO-105 aircraft called the Advanced Technology Testing Helicopter System (ATTheS). The aircraft, shown in Figure 21, began flying in 1982. It used the now familiar combination of an evaluation pilot on a non-redundant fly-by-wire system with a safety pilot on backdriven mechanical controls [43]. It included explicit model following and made many valuable contributions to the understanding of rotorcraft handling qualities over more than 1300 flight hours, prior to the tragic crash of the aircraft in 1995 (during a routine flight in mechanical control mode).



Figure 21. DLR Advanced Technology Testing Helicopter System (ATTheS).

In the 1980's, Aerospatiale, now part of Eurocopter, modified an AS365N Dauphine to include a duplex fly-by-wire system with a mechanical backup [48]. This aircraft flew for more than a decade before being retired to a museum in southern England. (Interestingly, prior to the fly-by-wire modifications, this aircraft—the first production SA365N, C/N 6001—was also used to set the speed record for

a round trip from Paris to London, delivering a baguette at an average speed of over 300 km/hr in 1980.)

All of these test aircraft, combined with countless hours of simulation and analytical studies, culminated in the late 1980's with the release of the ADS-33 requirements. ADS-33 provided clear requirements for the required response type as a function of mission tasks and the usable cue environment (UCE). In order of decreasing agility and increasing stability, the most important modes are: RCAH (Rate Command / Attitude Hold), ACAH (Attitude Command / Attitude Hold) and TRCPH (Translational Rate Command / Position Hold). Automatic turn coordination, even at low speed, is also of vital importance to reducing pilot workload.

THE PRODUCTION ERA BEGINS

By the end of the 1980's, it was clear that multi-mode, explicit model following control laws with a full-authority fly-by-wire flight control system were uniquely capable of providing Level-1 handling qualities for a variety of rotorcraft missions and operating conditions. The era of production fly-by-wire rotorcraft began in the spring of 1989, with the first flight of the V-22 Osprey tiltrotor. Digital fly-by-wire was a key technology for the tiltrotor, not only for the ability to tailor the control laws to the flight condition and nacelle configuration, but also to enable such features as the wing fold, which is crucial for the Osprey's shipboard operations.



Figure 22. The V-22 Osprey.

The V-22 employs many of the features discussed above, including a full-authority, triplex, self-monitoring digital flight control system with explicit model following control laws. A conventional center stick was chosen to reduce risk and reduce pilot training requirements. The implementation includes a PFCS providing flight-critical operations and an AFCS providing the additional augmentation

required for Level-1 handling qualities [49]. But the V-22 program has also achieved tremendous advances in technology in its own right, notably through the introduction of loads-limiting control laws [50].

The unique capabilities of the V-22, combining the speed and range of an airplane and the vertical take-off capability of a helicopter, create unique design challenges, requiring a balance of structural strength, weight, and control power parameters. The use of structural load limiting control laws was key to the successful navigation of these V/STOL challenges for the V-22. Using a combination of feed-forward and feedback control, load limiting is provided over the entire V-22 flight envelope without compromising Level-1 Handling Qualities. The effectiveness of the loads limiting control laws for differential mast torque during roll maneuvers is shown in Figure 23, taken from [50]. Other structural loads addressed with the control laws include trim and dynamic flapping, rotor yoke bending, and nacelle conversion actuator and vertical downstop loads.

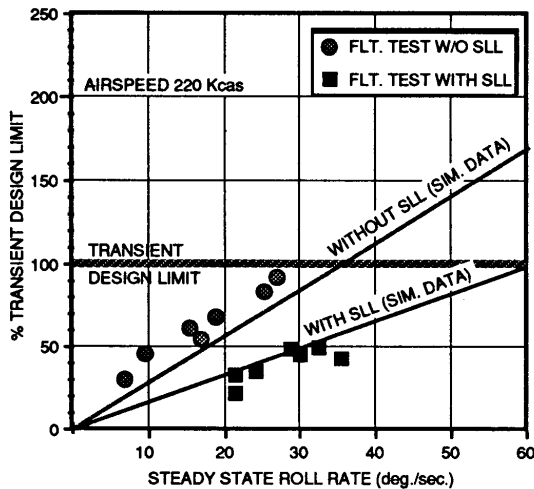

Figure 23. Effectiveness of V-22 Loads Limiting Control Laws Demonstrated in Flight Test Roll Maneuvers.

AGGRESSIVE FULL-ENVELOPE FLIGHT

When Boeing and Sikorsky teamed for the LHX competition, sharing of data from the ADOCS and SHADOW programs commenced, resulting in a solid foundation of understanding of control inceptors, controller configurations, and control laws for the Comanche.

Based on the experiments conducted on these platforms, the RAH-66 Comanche design incorporated a 3-axis, limited displacement, unique-trim sidearm controller for control of the longitudinal, lateral, and yaw axes (see Figure 24). A proportional collective with approximately 6 inches of displacement was used. An enhancement tailored to the scout mission was the incorporation of limited control in the vertical (fourth) axis of the sidearm controller. This allowed the pilot to command stabilized climbs and descents with the altitude hold system engaged. This was used primarily for vertical unmask and remask maneuvers, which enabled the pilot to fly through the autopilot without even temporary disengagement.



Figure 24. RAH-66 Comanche Sidearm Controller.

Pilot sensitivity to small changes in the mechanical characteristics of the controller was surprisingly high. The full motion simulator was used to assess a matrix of characteristics, including: displacement, breakout force, gradient, friction, and damping. A series of pilot trials, using ADS-33 mission task elements, was conducted to settle on the characteristics that would be employed in the production controller. In addition, the precise mounting scheme for the controller, which included angular position, height, adjustability, armrest location, size and adjustability were determined using baseline data from ADOCS [19] and verified during simulation trials. The development conducted in this area paid off, as the characteristics of the RAH-66 Comanche controller during flight test development were well received.

The Comanche also employed multi-mode explicit model following control laws, as shown in Figure 25. Ideally, the control system would be able to “know” the appropriate mode, but a design that offers this

capability without creating issues during mode transition or pilot awareness of moding has not yet been demonstrated in flight. The alternative approach was to offer the pilot “selectable modes.” The baseline mode, most appropriate for maneuvering flight, was rate command/attitude hold [38]. For those flight modes demanding high levels of stability, such as cruise or flight in low visibility or at night, attitude command/speed/level bank hold was offered [39]. In all cases, axis decoupling (including automatic turn coordination) was achieved by a combination of feed-forward, mixing, and feedback.

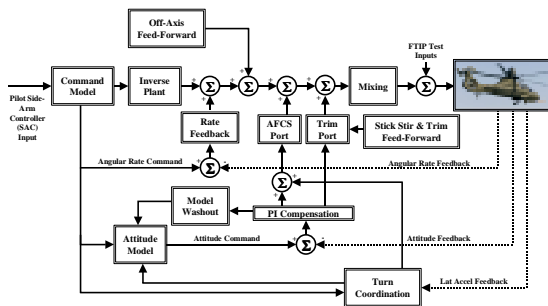

Figure 25. RAH-66 Comanche CAFCS Control Law Architecture.

The Comanche also made important advances in control law design for aggressive maneuvering throughout the flight envelope. One notable accomplishment during the more than 600 hours of flying the two prototype aircraft was the development of passive loads limiting in a manner which did not compromise the explicit model following (through angular acceleration limits) and actually improved the predictability of the response for rapid aggressive inputs [44]. Also, the full-time explicit model following was extended to full envelope capability, with no restrictions on pitch or roll attitudes, enabling aggressive combat and aerobatic maneuvers, as shown in Figure 26.

TAXI, TAKE-OFF & LANDING

The unique trim controller design presents challenges during the transition to and from, as well as operation on, the ground. In January 1974, the first flight of the F-16 took place unexpectedly, as the pilot aborted an unpredictable response during a high-speed taxi test by taking flight. This gave the industry a clear indication of the issues that might be posed by the higher sensitivity and different control strategies required with this type of controller.



Figure 26. RAH-66 Comanche Demonstrating Full-Envelope Capability with a Split-S Maneuver.

The helicopter poses even more challenges than the fixed wing because the rotor has the capability to provide lift and create pitching and rolling moments to the airframe anytime it is turning (the airplane only realizes these forces with sufficient airspeed, so no issues exist during start and taxi). The issue is simple: anytime the aircraft is in contact with the ground, external forces are in play which influence the ability of the stability system to do its job. If the aircraft is upset from the trim reference because it has encountered a change in slope of the terrain, the stability system will try to correct the upset – but it cannot because the aircraft is constrained by the ground. Additionally, the unique trim controller employs automatic retrim, known as trim followup, anytime the pilot makes an input. Obviously, if the

aircraft is constrained to the ground during pilot input, the retrim cannot take place, but the stability system will make every attempt to satisfy pilot command. This leads to the appearance of overcontrol, and in the case of the F-16 first flight, pilot induced oscillations (PIO).

The SHADOW research helicopter was utilized to conduct research into the requirements for the takeoff and landing transition [54]. From April to June of 1992, the aircraft flew 32 test sorties, completed over 400 takeoffs and landings to surfaces ranging from hard runway to soft grass, and on slopes from level to 8 deg side slope. The program investigated several technologies for detecting ground contact, as well as developing control laws to conduct smooth takeoff and landing transitions. Two significant findings resulted from this research: first, the importance of reliably detecting ground contact, and second, the methodology required to make mode changes to the control laws during ground transition.

The SHADOW research revealed the importance of detecting ground contact at very light weight. During landing, the desire was to retain as much of the stability as possible throughout the landing transition, and retain the same control strategy during landing as was used during in flight maneuvers. Several technologies were evaluated, including a ranging device to detect close proximity to the ground (vs actual ground contact). It was found that pilots were very sensitive to early or late mode changes, and the requirement evolved to a “weight on wheels” detector which would transition above at least 200 lbs of weight on wheels, but less than 500 lbs. Tolerance to side loads was essential. While there was some speculation these values might represent percent gross weight vs absolute thresholds, since the test vehicle and Comanche were approximately the same weight, it was decided to forgo any further investigation of that question. An additional factor noted in the ground detection system was the need for debounce. Once the aircraft made contact with the ground and the control moding began to transition, if the pilot bounced the aircraft in any way, it was important to hold the transition. To do otherwise created some interesting oscillatory inputs.

Control law mode changes, primarily in the areas of feedback and trim were a somewhat more complex problem than ground contact detection. Summarizing the results, it was found that it was desirable during landing to maintain limited authority rate feedback augmentation to suppress short term upsets during landing, while rejecting the higher authority attitude

feedback. Rate feedback was also rejected based on an “axis constrained” criteria, that is, once the axis (longitudinal, lateral, yaw) was constrained by ground contact, the feedback would be turned off. Trim follow up was the biggest challenge, as moding of this function would result in a change in pilot control strategy. Eventually it was found that “freezing” the trim upon ground contact actually improved pilot awareness of the control strategy requirements during landing. During slope landings, for example, the controller reverted to proportional response in the axis that was still airborne, allowing the pilot to “feel” how much input was being made against the rotation of the aircraft, which made for smoother landings and a higher degree of awareness as to the severity of the slope.

The takeoff sequence also experienced important changes in control law moding. Once again, if the mode change took place too early or too late, dramatic changes in pilot workload resulted. Since trim follow up was “frozen” during the landing, the potential existed for each takeoff to start with a different control (trim) position. This resulted in some rather large transients after liftoff, as the pilot commanded trim to the proper position. To counter this, during all landings the trim was forced to a neutral position. The controls were placed at the position for nominal hover, and trim follow up was not restored until the aircraft was airborne. This resulted in a feature similar to the slope landing, where the pilot could bias the proportional control during lift off, to anticipate wind for example, washing out the command to zero once achieving airborne state. The result was very smooth slope takeoffs, takeoffs in cross winds, and running takeoffs.

VEHICLE MANAGEMENT SYSTEMS

As stated earlier, the unique capabilities of the full authority fly-by-wire system make it more important than ever to integrate the crew interface design to the control system. Modern crew resource management training emphasizes the critical need to maintain situation awareness. The question often heard in the automated cockpit is “what is the system doing now?”. During development, it was found that the following features must be incorporated into the crew interface:

- the pilot must be aware of control system mode, and when automated transitions are being made
- the pilot must be aware of the trim parameter (ie, airspeed), and current value being held

- the dynamics of any cueing symbology must match the control system.

An example of cueing found in the Comanche helicopter was the use of symbology to convey to the pilot moding from attitude command, to translational rate command, and hover hold capture. A velocity vector/acceleration cue was provided similar to other tactical helicopters (see Figure 27). A circle indicated that the Velocity stabilized control laws were selected on, and hover hold was armed. The size of the circle indicated the threshold velocity the pilot must decelerate below before the system would engage hover hold. Once the vector was inside the circle, the system would fill the acceleration cue to indicate that all other constraints had been satisfied, and the pilot needed to release the controller to neutral to allow the system to engage hover. Once the system completed the deceleration to zero velocity, a position reference was established and the aircraft stabilize in hover. At that point, the **HVR** light on the flight control panel illuminated, letting the pilot know the aircraft position was stable.

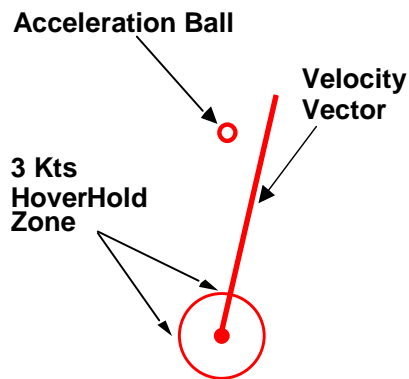

Figure 27. RAH-66 Comanche Velocity Vector / Acceleration Cueing Symbology.

Probably the most important aspect of the unique trim approach that must be supported by cueing is control system limit encroachment. Since the unique trim system is always “centered”, the pilot can put the aircraft into a position where the controls are near a limit, but the physical position of the controller is neutral. This requirement led to the development of the envelope cueing system for Comanche. The system used a combination of visual and aural cues to make the pilot aware of limit encroachment. (The details of this system were described previously [20].) In an aircraft with excess control power, like Comanche, this is probably acceptable; however other systems must be tailored to the characteristics,

limitations, and missions of other applications. The development of controllers with active feedback will likely improve pilot cueing.

Other important aspects of an advanced vehicle management system include integration of flight controls with other segments, including engine control and, for the combat mission, fire control. Additional details of advanced VMS are in [17].

GLOBALIZATION

This paper has emphasized the developments in the United States, with which the authors are most familiar. But, especially in the past decade, the rotorcraft industry has seen the rapid globalization of fly-by-wire technology.

The NH-90, a new NATO cargo helicopter built by a consortium of Agusta, Eurocopter, and Fokker, was designed with fly-by-wire flight controls [46, 45]. In December 2003, a fly-by-wire prototype NH-90 flew for the first time without mechanical backup. The first serial production machine with full fly-by-wire flew in May 2004, and was shortly thereafter ceremonially delivered to the Germany Army operator at the ILA in Berlin.



Figure 28. The NH-90 Recently Began Flying Under Fly-by-Wire Flight Controls Without Mechanical Backup.

The Euromil Mi-38, produced by a consortium of Eurocopter, Mil, and Kazan Helicopters, with propulsion by Pratt & Whitney of Canada, made its first flight on 22 December 2003. Scheduled for production in 2007, it evidently includes a triplex fly-by-wire system, as well as many other advanced technologies. Kazan’s Ansat aircraft is also reported to employ fly-by-wire flight controls.

Fly-by-Wire research and development is also ongoing at Kawasaki Heavy Industries in Japan.

ONGOING RESEARCH & DEVELOPMENT

Rotorcraft handling qualities research with variable stability, fly-by-wire, in-flight simulation continues at the NRC with the Bell 412 ASRA [47], at NASA with the RASCAL program [23] and at the DLR with the ACT-FHS (quad-redundant fly-by-light) effort [51].

The Helicopter Active Controls Technology (HACT) program is demonstrating the next generation of flight controls technology, including quantifiable advancements in affordability and reduction in cycle time, for current and future rotorcraft [52]. Important features of the HACT system include task-tailored control laws, carefree maneuvering, limit prediction and active cueing. HACT is to be flight demonstrated on the AH-64D Apache Longbow, with the full authority digital, triply redundant VITAL (VMS Integrated Technology for Affordable Life cycle costs) serving as the baseline flight control system. Many of the features of HACT can be suitably implemented on the current fleet of aircraft within the existing limited-authority architecture, providing immediate and significant improvements in mission effectiveness and safety.

As a result of these and other ongoing research and development efforts, the future may see the following technologies becoming routinely implemented as important parts of integrated fly-by-wire flight control and vehicle management systems:

- Point in space precision approaches in Category III weather
- Automatic landing in brown out conditions
- Active cueing to enable carefree maneuvering
- Regime recognition with task-tailored control laws
- Sling load active stabilization
- Coupled terrain following/obstacle avoidance using wideband sensor input
- Fully integrated flight and engine control

CONCLUSIONS

Fly-by-wire design offers a number of enhancements over conventional controls. Weight and mechanical complexity can be reduced through elimination of components such as trim servos, mixer assemblies, and pushrods. Direct maintenance costs are reduced because servicing, rigging, and parts replacements are notably lower with a digital system. Greater reliability and advanced flight functions with higher levels of augmentation are also possible, resulting in

better safety, lower pilot workload and more aggressive and precise maneuvering. In short, fly-by-wire dramatically improves mission effectiveness.

For all of these reasons, rotorcraft digital fly-by-wire flight controls have gained acceptance around the world. The technical advantages of fly by wire are indeed “impossible to resist.”

ACKNOWLEDGEMENTS

The authors gratefully acknowledge the assistance of Bruce McManus, Technical Fellow, the Boeing Company.

REFERENCES

1. Reeder, J.P., and F.B. Gustafson, “Notes on the Flying Qualities of Helicopters,” American Helicopter Society 4th Annual Forum, Philadelphia, PA, April 1948. See also NACA Technical Note 1799, January 1949.
2. Hohenemser, K., “Contribution to the Problem of Helicopter Stability,” American Helicopter Society 4th Annual Forum, Philadelphia, PA, April 1948.
3. Mazur, J.W., “Flight Testing of Helicopters by the U.S. Navy,” American Helicopter Society 5th Annual Forum, New York, NY, May 1948.
4. DeVore, G., “A Discussion of CAA Policies, Flight Test Procedures and Civil Air Regulations for Helicopters,” American Helicopter Society 7th Annual Forum, Washington, DC, April 1951.
5. Bohling, R.F., “Helicopter Instrument Flight Operations,” American Helicopter Society 12th Annual Forum, Washington, DC, May 1956.
6. Erickson, F.A., G. Spratt, “A New Approach to Helicopter Stability,” American Helicopter Society 9th Annual Forum, Washington, DC, May 1953.
7. Kelley, B., “Accelerometer Control,” American Helicopter Society 10th Annual Forum, Washington, DC, May 1954.
8. Gerstenberger, W., Carter, E.S., “Closing the Loop on the Automatic Stabilization Equipment,” American Helicopter Society 13th Annual Forum, Washington, DC, May 1957.
9. Kendall, Jr., D.E., “Automatic Control of Helicopters,” American Helicopter Society 10th Annual Forum, Washington, DC, May 1954.

10. Blake, B. et al., "Recent Advances in Flying Qualities of Tandem Helicopters," American Helicopter Society 14th Annual Forum, Washington, DC, April 1958.
11. Sissingh, G.J., "The Frequency Response of the Ordinary Rotor Blade, the Hiller Servo-Blade, and the Young-Bell Stabiliser," *RAE Reports and Memoranda No. 2860*, May 1950. See also Sissingh, G.J., AHS 8th Annual Forum, 1952.
12. Edenborough, H.K., K.G. Wernicke, "Control and Maneuver Requirements for Armed Helicopters," American Helicopter Society 20th Annual Forum (*Proceedings Supplement*), Washington, DC, May 1964.
13. Hoh, R., et al., "Background Information and User's Guide for ADS-33," USAAVSCOM Technical Report 89-A-008, Dec 1989.
14. Seckel, E., "Stability and Control of Airplanes and Helicopters," Academic Press, New York, 1964. Pages 388-389.
15. Deardorff, J.C., A.L. Freisner, N. Albion, "Flight Test Development of the Tactical Aircraft Guidance System," American Helicopter Society 29th Annual Forum, Washington, DC, May 1973.
16. Kilmer, F.G., J.R. Sklaroff, "Redundant System Design and Flight Test Evaluation for the TAGS Digital Control System," American Helicopter Society 29th Annual Forum, Washington, DC, May 1973.
17. Landis, K.H., J.M. Davis, C. Dabundo, J.F. Keller, "Advanced Flight Control Technology Achievements at Boeing Helicopters," *International Journal of Control*, Vol. 59, No. 1, 1994, pp. 263-290.
18. Stiles, L., Lappos, N. "Evaluation of 4-Axis Sidearm Controller in the National Research Council of Canada Bell 205A-1 Helicopter, Internal report, 9-10 Nov 87.
19. Glusman, S.G., et al., "Handling Qualities Evaluation of the ADOCS Primary Flight Control System," American Helicopter Society 42nd Annual Forum, Washington, DC, June 1986.
20. Mayo, J.R., and Iannacci, V.N., "The RAH-66 Comanche Flight Envelope Cueing System," American Helicopter Society 55th Annual Forum, Montreal, Canada, May 1999.
21. Dabundo, C., et al., "Flying Qualities Evaluation of the V-22 Tiltrotor," American Helicopter Society 47th Annual Forum, May 1991.
22. King, D.W., et al., "V-22 Load Limiting Control Law Development," American Helicopter Society 49th Annual Forum, St. Louis, MO, May 1993.
23. Dones, F., et al., "An Advanced Fly-By-Wire Flight Control System Designed for Airborne Research – Concept to Reality," American Helicopter Society 56th Annual Forum, Virginia Beach, VA, May 2000.
24. Davis, J.M., et al., "Development of Heavy Lift Helicopter Handling Qualities for Precision Cargo Operations," American Helicopter Society 31st Annual Forum, Washington, DC, May 1975.
25. Hutto, A.J., "Flight-Test Report on the Heavy-Lift Helicopter Flight-Control System," American Helicopter Society 31st Annual Forum, Washington, DC, 1975.
26. Simon, D.R., J.C. Savage, "Army Preliminary Evaluation of the HLH ATC Demonstrator Fly-By-Wire Flight Control System," American Helicopter Society 31st Annual Forum, 1975.
27. McManus, B.L., A.J. Niven, "Heavy-Lift Helicopter Primary Flight Control System," American Helicopter Society 31st Annual Forum, Washington, DC, 1975.
28. Curtiss, Jr., H.C., "Rotorcraft Stability and Control, Past, Present and Future: The 20th Annual Alexander A. Nikolsky Lecture," American Helicopter Society *Journal*, January 2003.
29. Prouty, R.W., H.C. Curtiss, Jr., "Helicopter Control Systems: A History" *AIAA Journal of Guidance, Control and Dynamics*, Vol. 26, No. 1, January-February 2003.
30. McManus, B.L., "Fly-by-Wire for Vertical Lift," *Journal of the American Helicopter Society*, Vol. 24, No. 5, October 1979.
31. Whalley, M., J. Howett, and S. Clift, "Optimization of Partial Authority Automatic Flight Control Systems for Hover/Low-Speed Maneuvering in Degraded Visual Environments," American Helicopter Society 55th Annual Forum, Montreal, Canada, 1999.
32. Sahasrabudhe, V., et al., "Modernized Control Laws: From Design to Flight Test," American Helicopter Society 4th Decennial Aeromechanics Technical Specialists' Meeting, San Francisco, CA, January 2004.

33. Boczar, B., D. Borgstrom, and P. Everett, "Key Aspects and Attributes of the RAH-66 Comanche Flight Control System," American Helicopter Society 55th Annual Forum, Montreal, Canada, 1999.
34. Cooper, D.E., "YUH-60A Stability and Control," *Journal of the American Helicopter Society*, July 1978.
35. Wright, G.P., N.Lappos, "Spirit Helicopter Handling Qualities Design and Development," American Helicopter Society 35th Annual Forum, Washington, DC, May 1979.
36. Amer, K.B., et al., "Handling Qualities of Army/Hughes YAH-64 Advanced Attack Helicopter," American Helicopter Society 34th Annual Forum, Washington, DC, 1978.
37. Ferguson, S.W., K.E. Bulta, "Development of a Fly-by-Wire Elevator for the Bell Helicopter Textron 214ST," American Helicopter Society 35th Annual Forum, Washington, DC, 1979.
38. Fogler, Jr., D.L., and J.F. Keller, "Design and Pilot Evaluation of the RAH-66 Comanche Core AFCS" Piloting Vertical Flight Aircraft: A Conference on Flying Qualities and Human Factors, San Francisco, CA, January 1993.
39. Gold, P.J. and J.B. Dryfoos, "Design and Pilot Evaluation of the RAH-66 Comanche Selectable Control Modes," Piloting Vertical Flight Aircraft: A Conference on Flying Qualities and Human Factors, San Francisco, CA, January 1993.
40. Landis, K.H. and S.I. Glusman, "Development of ADOCS Controllers and Control Laws, Final Report, Volume 3, Simulation Results and Recommendations," D210-12323-3, AVRADCOM Contract NAS2-10880, July 1984.
41. Stengel, R.F., et al., "Digital Flight Control Design for a Tandem-Rotor Helicopter," *Automatica*, Vol. 14, pp. 301-312, 1978.
42. Hindson, W.S., "New Capabilities and Recent Research Programs of the NASA/Army CH-47B Variable Stability Helicopter," American Helicopter Society 42nd Annual Forum, Washington, DC, 1986.
43. Pausder, H.-J., et al., "ATTHES In-Flight Simulator for Flying Qualities Research," European Rotorcraft Forum, 1991.
44. Kothmann, B.D. and J. Armbrust, "RAH-66 Comanche Core AFCS Control Law Development: DEMVAL to EMD," American Helicopter Society 58th Annual Forum, Montreal, Canada, 2002.
45. Ferrigno, A., "Integration and Validation for NH-90 Fly-by-Wire," European Rotorcraft Forum, 2000.
46. Vidal, P.A., "NH-90 Helicopter Fly-by-Wire Flight Control System," American Helicopter Society 53rd Annual Forum, Virginia Beach, VA, 1997.
47. Ellis, D.K. and A.W. Gubbels, "Development and Flight Testing of a Command Validation Algorithm for a Simplex Fly-By-Wire Helicopter," American Helicopter Society 55th Annual Forum, Montreal, Canada, 1999.
48. Delestrade, P., and J.M. Massimi, "Preliminary Evaluation of New Control Laws on the Experimental Fly-by-Wire Dauphin Helicopter," European Rotorcraft Forum, 1990.
49. Dabundo, C., J. White, and M. Joglekar, "Flying Qualities Evaluation of the V-22 Tiltrotor," American Helicopter Society 47th Annual Forum, May 1991.
50. King, D.W., et al., "V-22 Load Limiting Control Law Development," American Helicopter Society 49th Annual Forum, St. Louis, MO, May 1993.
51. Kaletka, J., "FHS: The New Research Helicopter: Ready for Service," European Rotorcraft Forum, 2003.
52. Miller, D.G., et al., "HACT Flight Control System (HFCS) Control Law Overview," American Helicopter Society 58th Annual Forum, Montreal, Canada, 2002.
53. Emiro, P.J., "SHADOW," American Helicopter Society 42nd Annual Forum, Washington, DC, 1986.
54. Bauer, C.J., "A Landing and Takeoff Control Law for Unique-Trim Fly-by-Wire Rotorcraft Flight Control Systems," Lichten Award Presentation at the American Helicopter Society 49th Annual Forum, Washington, DC, 1993.