

TECHNICAL DEVELOPMENT PLAN

MEDIUM TRANSPORT HELICOPTER
3 TON 'CHINOOK'
CH-47A HC-1B

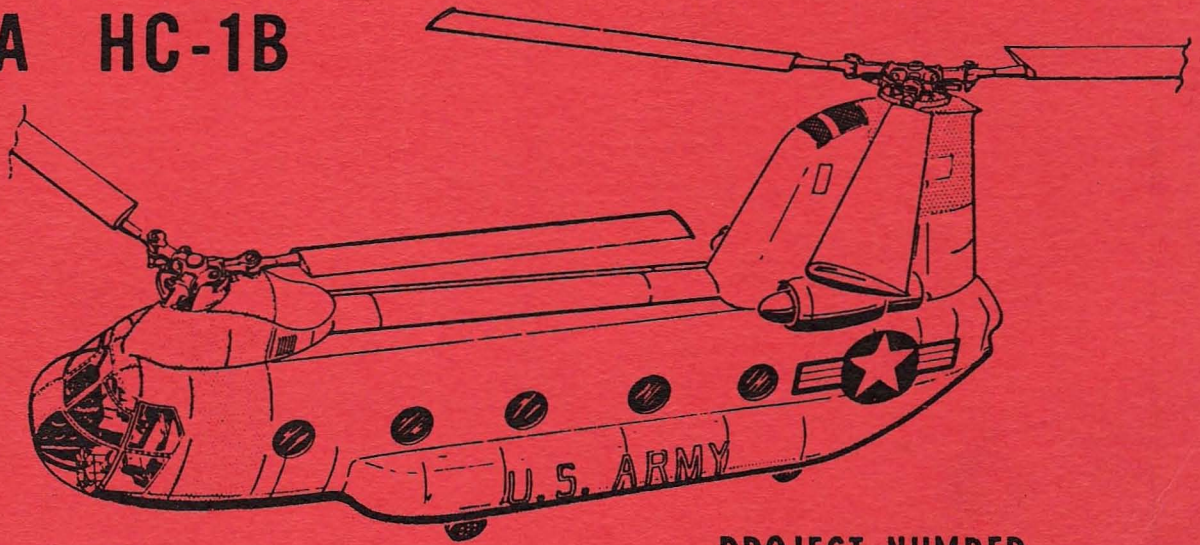

PROJECT NUMBER

1-R-1-79191-D-685

(WAS 9M38-13-012)

AMC CODE: 5183-12-644

U. S. ARMY
MATERIEL COMMAND

REVISION 1 JAN 1964

FOR OFFICIAL USE ONLY

TECHNICAL DEVELOPMENT PLAN
MEDIUM TRANSPORT HELICOPTER (3 TON) (CHINOOK)
CH-47A (HC-1B)

PROJECT NO.	1-R-1-79191-D-685 (formerly 9M38-13-012)
AMCMS CODE	5183-12-644
AMC ELEMENT CODE	6-71-91-91-1
PRIORITY	1
DATE ESTABLISHED	2 July 1959

Distribution List - Appendix I

Detailed Technical Reports - Appendix II

Cognizant Agency:

U. S. ARMY MATERIEL COMMAND

This revision is the concluding issue of the CH-47A (HC-1B) Technical Development Plan. It supersedes all previous issues.

FOR OFFICIAL USE ONLY

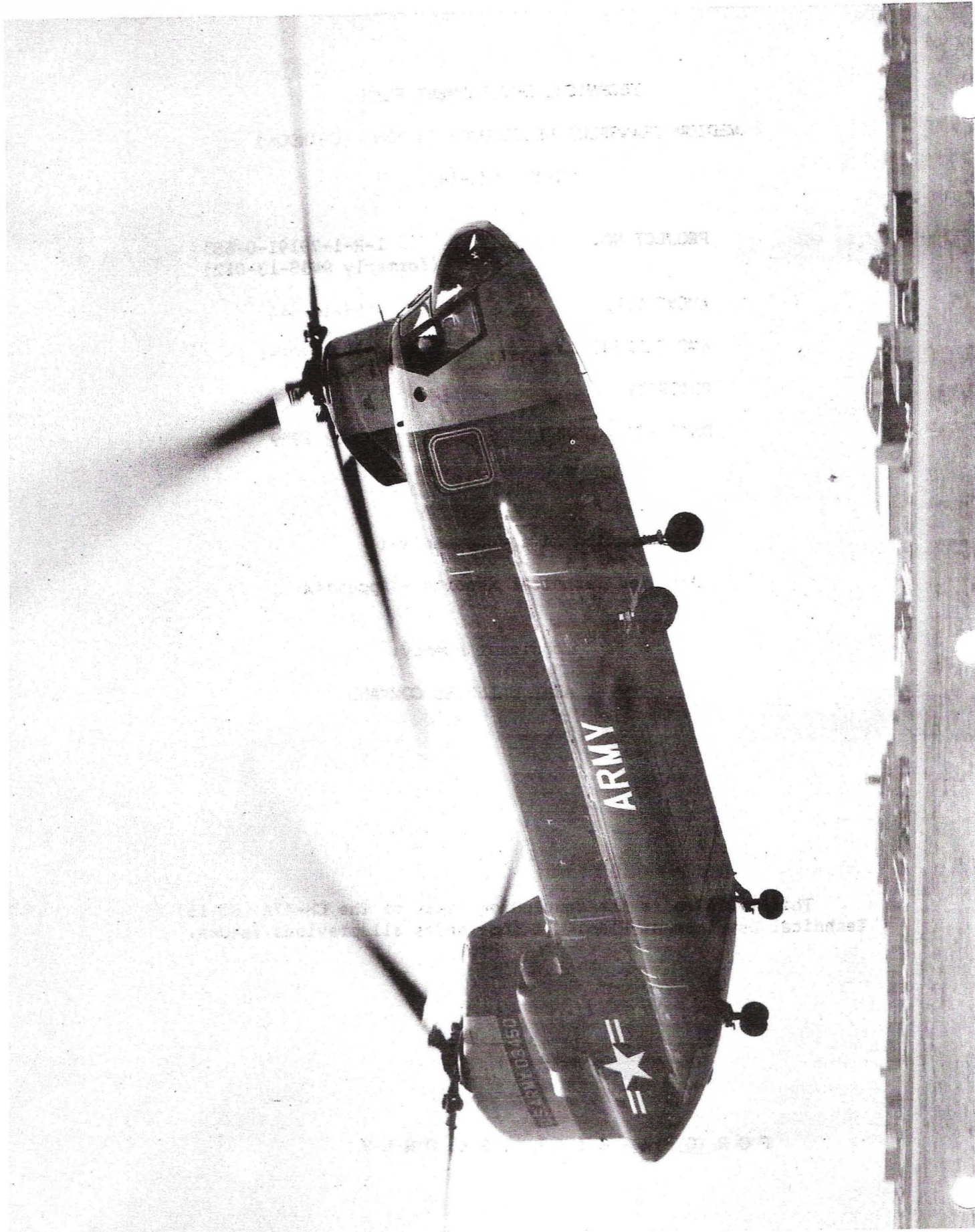

FOR OFFICIAL USE ONLY

TABLE OF CONTENTS

	Page
Responsible Project Officer	5
<u>SECTION I - NARRATIVE SUMMARY</u>	
1. Statement of Requirements	6
2. Scope and Objectives	7
3. Development Plan	8
4. Major Significant Occurrences	9
<u>SECTION II - DETAILED DEVELOPMENT PLAN</u>	
1. Description of End Items	17
2. Performance Characteristics	29
With T55-L-5 Engine	29
With T55-L-7 Engine	30
3. Status of Military Characteristics (MC) Kits	31
4. Schedule of Development	31
5. RD Milestones	31
6. Five Part Manual Schedule	32
7. Government Facilities Available	32
8. Construction Requirements	32
<u>SECTION III - RELIABILITY PROGRAM AND MAINTAINABILITY PROGRAM</u>	
1. Operational Information That Affects Reliability and Maintainability Design	39
2. Planning Information Needed for Reliability and Maintainability Design	40
3. Plans for a Reliability Program Outlining How Reliability Will Be Achieved	42
4. Plans for a Maintainability Program Outlining How Maintainability Will Be Achieved	44

F O R O F F I C I A L U S E O N L Y

	Page
<u>SECTION IV - FUNDING AND CONTRACTS</u>	
1. Prior, Current and Planned Fiscal Year Funding and Obligations	46
2. List of Major Prime Contracts and Contractors	49
3. List of Major Subcontractors	50
<u>APPENDIX I - DISTRIBUTION</u>	51
<u>APPENDIX II - DETAILED TECHNICAL REPORTS</u>	61

FOR OFFICIAL USE ONLY

RESPONSIBLE PROJECT OFFICER

Col. E. B. Bissell
Project Manager, CHINOOK
Hq, Army Materiel Command
Telephone No. OX-76023 or 74362

FOR OFFICIAL USE ONLY

SECTION I

NARRATIVE SUMMARY

1. Statement of Requirement:

a. A Department of the Army requirement exists for a transport helicopter with normal payload of 3 tons with an operating radius of 100 nautical miles.

b. Late in 1956 the Department of the Army announced plans to ultimately replace its piston powered transports with turbine powered equipment and to develop a new multi-turbine medium helicopter transport. Task initiated September 1957. Nonavailability of funds precluded any work during 1957. By June 1958 prospective airframe contractors received invitations to submit design proposals for the new medium transport helicopter. A source selection competition was held at Wright Air Development Center (WADC), Wright-Patterson Air Force Base, Ohio, during August and September 1958. Findings of the source selection were submitted to the Department of the Army in October 1958. The Department of the Air Force was advised of Army approval of these findings and the subsequent development program in February 1959. On 4 March 1959, the Department of the Army announced that Vertol Division, Boeing Airplane Company, Morton, Pennsylvania, design proposal had been accepted and requested the U. S. Air Force to solicit a formal aircraft proposal from Vertol. In April 1959 this proposal was submitted, and on 22 May 1959 Letter Contract AF 33(600)39492 was awarded. The definitive contract was signed 27 June 1960. The requirement for a medium transport helicopter has been expressed in Section 533a, Paragraph 16, of the Combat Development Objectives Guide. (CDOG)

FOR OFFICIAL USE ONLY

2. Scope and Objectives

The immediate objective is to design and develop a medium transport helicopter of 3 ton capacity. The ultimate objective is to type classify the item as standard Army equipment.

a. Approach:

- (1) Conduct necessary preliminary design studies.
- (2) Develop the most promising design.
- (3) Construct necessary prototypes.
- (4) Conduct appropriate engineering and user tests.
- (5) Accomplish necessary modification and retests.
- (6) Specifically review the item during the development phases for maximum use of standard components.
- (7) Prepare suitable reports as required.
- (8) Accomplish necessary type classification action.

b. Description of principles of operation and performance characteristics: The helicopter will be employed as a means of aerial transportation for troops, supplies and equipment, including aeromedical evacuation and heavy lift in tactical and logistical operations in the field Army areas. It will be capable of operation under instrument flight conditions. See Section II Paragraph 2 for performance characteristics.

c. Operational concept of usage: See pages 12 thru 16.

d. Item replacement: The CH-47 helicopter will replace the CH-37 and to some extent, the CH-21 and CH-34. The advantages are improved performance, productivity and mechanical reliability.

e. Prior fiscal obligations for Fiscal Years 59, 60 and 61 and obligations to date for FY 62. See Page 46. Planned funding to complete program. See Pages 46 and 47.

F O R O F F I C I A L U S E O N L Y

3. Development Plan: The development plan for the Chinook helicopter specifies initiation of procurement of five YCH-47A and five CH-47A aircraft in Fiscal Years 1959 and 1960. Production of the CH-47A aircraft was programmed to commence in Fiscal Year 1961. The overall Development Plan for the YCH-47A aircraft is shown in Section II, Paragraph 4. The first aircraft shop completion was originally scheduled for November 1960. However, as a result of Contract Change Notice No. 4, dated 10 February 1960, the engine was uprated to 2200 HP, and the drive system was uprated to 4400 HP, which resulted in a shift in the shop completion date to March 1961. As a result of various difficulties encountered by the contractor, the first aircraft was shop completed on 28 April 1961. Of major significance in the YCH-47A development program is the aircraft tooling concept. In order to minimize overall cost and eliminate delay following the fabrication of the first ten aircraft, the aircraft and its tooling were designed for an accelerated production rate. Thus, when production is accelerated, it will not be necessary to redesign the aircraft or the tooling in order to achieve the desired rate. With this concept, it is believed that the initial ten aircraft will be produced at a minimum cost.

a. Work: All manufacturing work will be accomplished by Vertol Division of Boeing Company, the prime contractor. The cognizant agency is the U. S. Army Materiel Command, Chinook Field Office, St. Louis, Mo.

b. Joint programming aspects: The Navy has plant cognizance over the prime contractor at Morton, Pennsylvania. The Air Force is the procuring agency for the aircraft and will conduct Category II, flight testing at Vertol Division of Boeing Company in Morton, Pennsylvania. The Army will conduct Category III, Phase "E" User Tests and Phase "F" Logistical Evaluation Tests. Category I tests are being conducted by the contractor.

c. First flight: Limited hover of the CH-47 took place on September 6 1961. First flight demonstration was held at Vertol on 19 October 1961.

d. Inspections:

(1) The "Preliminary Cockpit Mockup Development Engineering Inspection" was held at Vertol, 19 and 20 November 1959.

(2) The "Mockup Inspection" (aircraft) took place at Vertol, 29 January 1960.

F O R O F F I C I A L U S E O N L Y

(3) The "Cockpit Lighting Mockup Inspection" took place at Vertol, 5 May 1962.

(4) The "Flight Safety Inspection" (FSI) took place at Vertol on #2 aircraft, 6 and 7 July 1961.

(5) The "Maintenance Engineering Inspection" (MEI) was held at Vertol on #4 aircraft, 7-9 March 1962.

(6) The Contractor Technical Compliance Inspection" (CTCI) took place at Vertol on #11 aircraft, 18-20 July 1962.

(7) The maintenance package finalization review was held at Ft Rucker, Alabama, on 9-18 September 1963.

4. Major Significant Occurrences:

a. On 12 July 1961, YCH-47A aircraft No. 1 was undergoing preliminary ground tests when the dephasing sleeve in the combining gear box became disengaged. The forward and aft rotor blades interfered, causing destruction of all blades, the aft pylon, aft transmission, and associated components. Further testing of No. 1 was delayed which resulted in rescheduling tests on subsequent aircraft.

b. The first 150 hour tie-down test was completed on 14 June 1962. However, a re-run was required because (1) failures occurred in the first stage planet bearing cages on the forward and aft transmissions and (2) excessive spacer wear in the engine transmission allowed the ring gear to fail and penetrate the housing. This re-run was completed 20 September 1962, and the aircraft officially qualified to the 150 hour specification requirement.

c. Climatic hangar tests were conducted on YCH-47A aircraft #4 at Eglin AFB, Florida in July through September 1962. These tests, which subjected the helicopter to icing conditions and temperatures ranging from +125°F to -65°F, revealed the need for improvements in the rotor blades, APU/AGB drive system, utility hydraulic system, heating system, insulation attachment, manual engine control, and other areas. Climatic Hangar Tests were re-run on YCH-47A aircraft #4 at Eglin AFB, Florida, 4 April - 10 May 1963, to determine adequacy of corrective action as result of previous test. Test temperatures ranged from +125°F to -65°F to ascertain the suitability of the entire aircraft with emphasis on rotor blades, APU/AGB drive, hydraulic systems, engine starting, and the heater. Corrective action taken on major low temperature problems were suitable in many cases. Some high and low temperature problems existed which were corrected prior to the Arctic Tests (Winter 1963) and desert test (Summer 1963).

d. Aircraft #11 was the first production aircraft accepted by the Army. Date of acceptance was 19 December 1962.

F O R O F F I C I A L U S E O N L Y

e. The service test (Phase E) was initiated on helicopter #8 by the Aviation Test Board in December 1962. Also, the Logistical Evaluation was begun during the same month using helicopters #9 and #10.

f. Compatability Tests were conducted on the Pershing Missile System at Orlando, Florida and Ft Bragg, North Carolina. The Chinook successfully transported all components of the Pershing Weapons System at that time.

g. During May 1963, initial tests were conducted by the AE & SW Board at Fort Bragg, North Carolina. A large variety of loads were successfully transported by the Chinook. External loads were carried on the cargo hook and loads of a wide variety were carried internally. The CH-47A was also successfully used to deliver paratroopers.

h. Beginning in June 1963 CH-47A helicopters were delivered to Ft Benning, Ga for utilization in the Project TEAM exercise.

i. On 25 October 1963 the CH-47A was type classified as Standard "A".

F O R O F F I C I A L U S E O N L Y

BLANK PAGE

FOR OFFICIAL USE ONLY

YCH-47. - CH-47 MISSION PROFILES

Standard Atmosphere

Zero Wind Condition

Model Spec 114-X-301, dated 1 Aug 63

(T55-L-7 Engines)

MISSION I

Deliver 6,000 pounds of internal payload to any point 100 nautical miles distant and return with 3,000 pounds of internal payload.

Avg. Outbound Cruise
Speed = 130 Knots
Cruise Time = 46 Min.

Avg. Return Cruise
Speed = 130 Knots
Cruise Time = 46 Min.

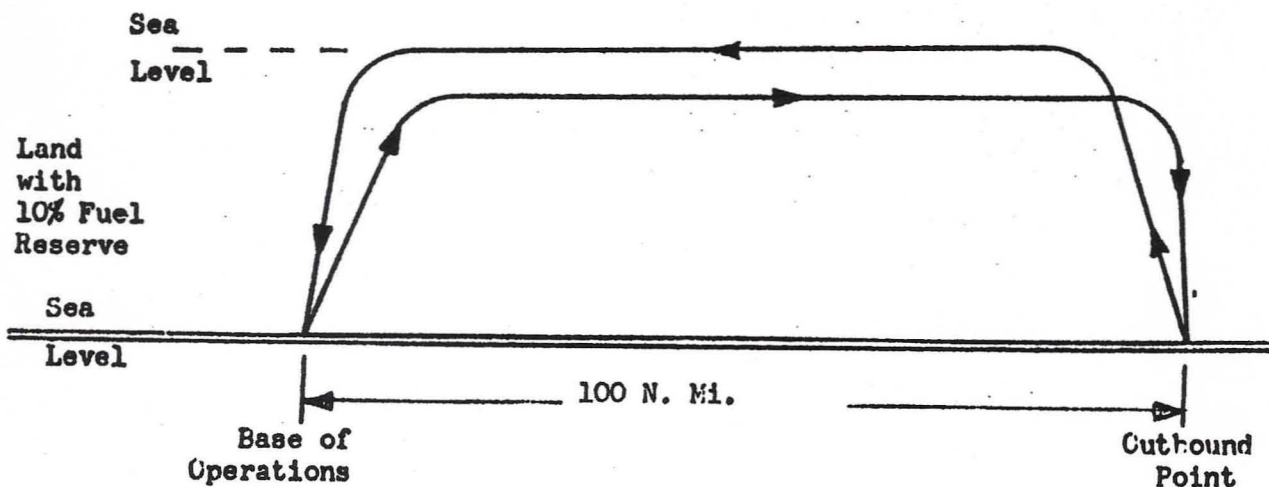

Initial G.W. = 28,200#
Initial Cargo = 6000#
2 Min. W/U

Land Unload
3000# Cargo
2 Min. W/U

Hovering @ 6000 Ft. for 5 minutes (OGE) @ 95 F (Guaranteed)

YCH-47, - CH-47 MISSION PROFILES

Model Spec 114-X-301 dated 1 Aug 63

Standard Atmosphere

Zero Wind Condition

(T55-L-7 Engines)

MISSION II

Deliver 13,600 pounds of external payload to any point 20 nautical miles distant and return. Equivalent Flat Plate Drag of External Cargo = 26 Sq. Ft.

Avg. Return Cruise
Speed = 130 Knots
Cruise Time = 9.0 Min.

Avg. Outbound Cruise
Speed = 100 Knots
Cruise Time = 12.0 Min.

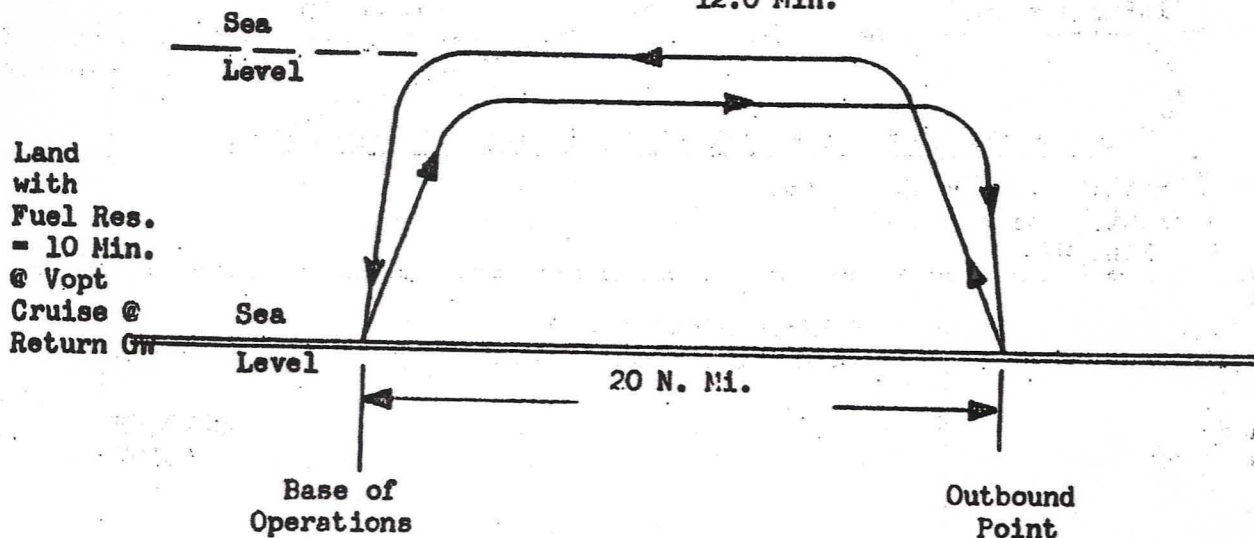

Initial G.W. 33000 Lbs
Initial Cargo 13600 Lbs
2 Min. W/U

Land Unload
13600 Lbs.
Cargo
2 Min. W/U

Hovering @ S. L. - Std. Atmos. with external payload, outbound only,
for a radius of 20 Nautical Miles.

FOR OFFICIAL USE ONLY

YCH-47, - CH-47 MISSION PROFILES

Model Spec 114-X-301 dated 1 Aug 63
Standard Atmosphere Zero Wind Condition
(T55-L-7 Engines)

MISSION III Ferry Range of 862 nautical miles without refueling
Land with 10% fuel reserve

Cruise 200 N. Mi. @ 5000 Ft. @
124 Knots Average Cruise Speed
Cruise Time = 1 HR. 02 MIN.

Cruise 725 N. Mi. @ 10000 Ft. @
125 Knots Average Cruise Speed
Cruise Time = 5 Hrs. 46 Min.

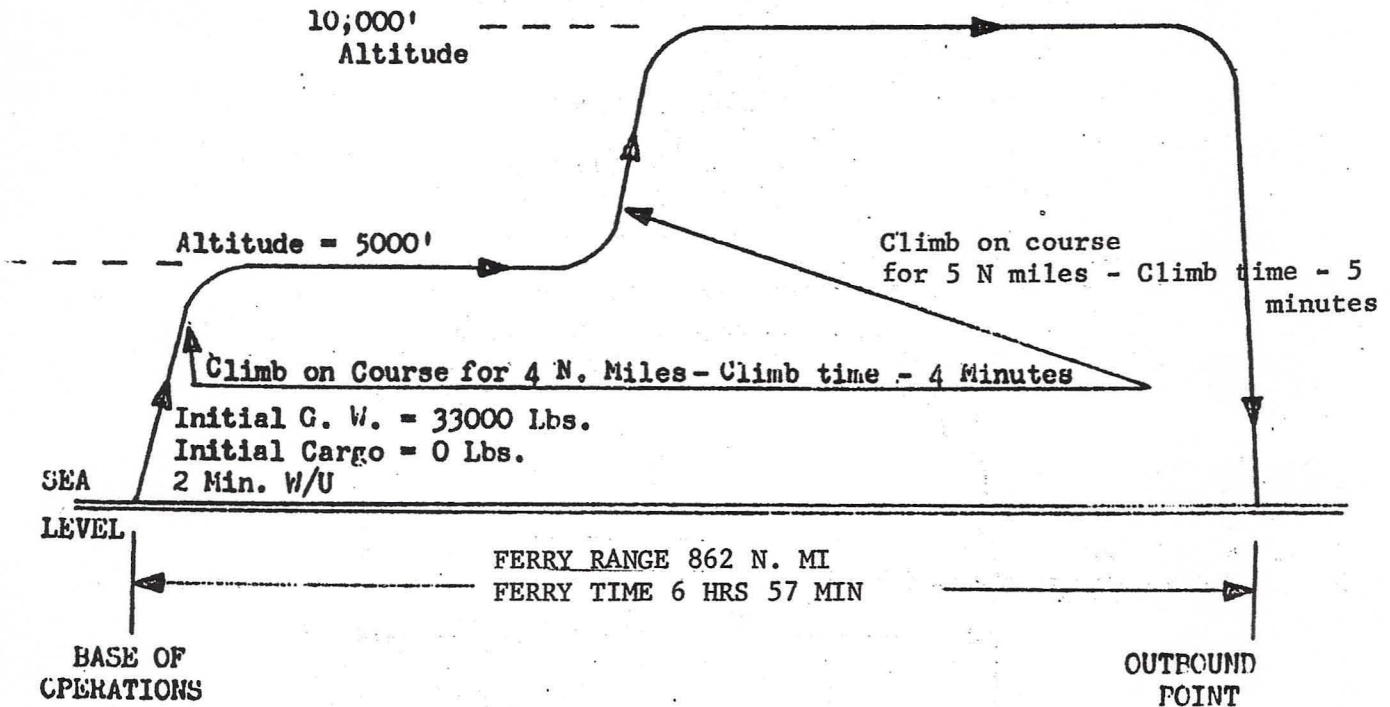

Hovering @ S. L. - Std. Atmos. with internal fuel and oil tankage for maximum Ferry Range.

FOR OFFICIAL USE ONLY

MISSION NOMOGRAPH

(APPROXIMATE)

TAKE-OFF GROSS WEIGHT VS. MISSION RADIUS AND HOVER CEILING

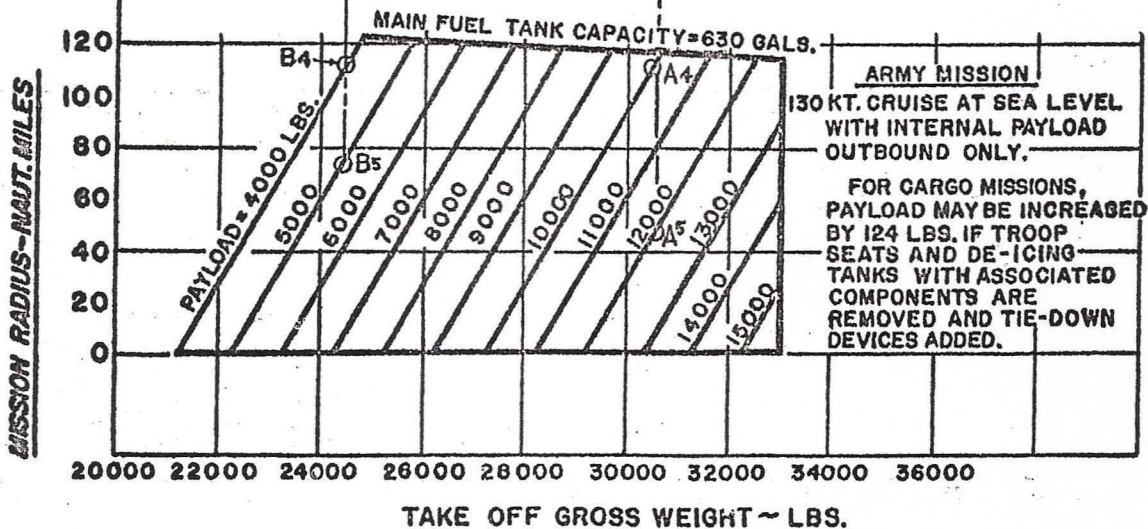
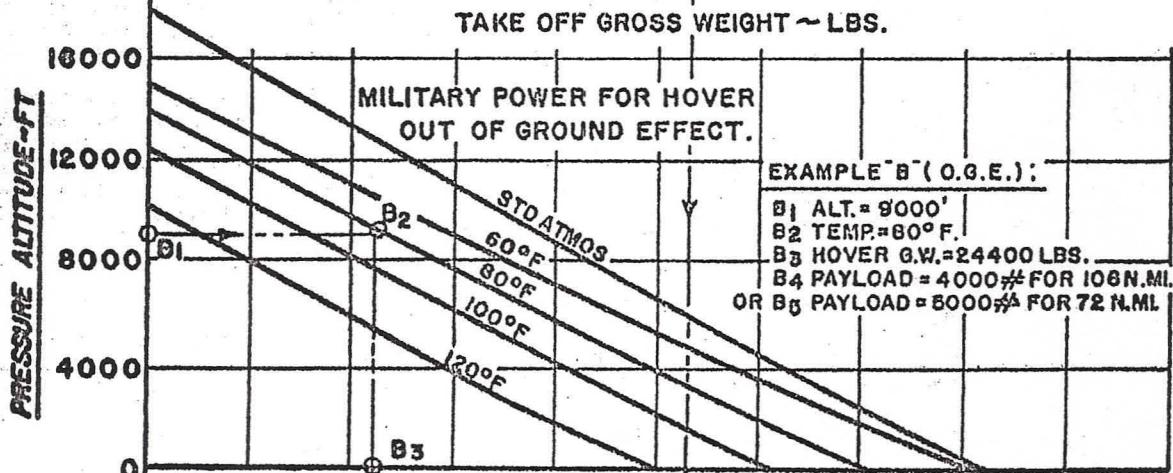
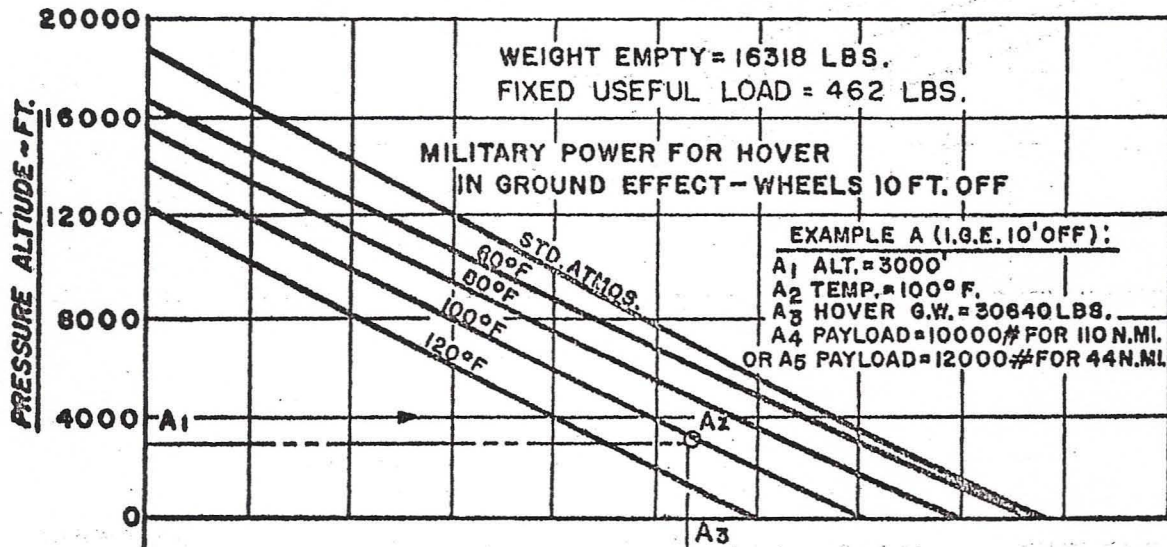

FOR OFFICIAL USE ONLY

CH-47A WITH T55-L-7 ENGINE
 HOVER CEILING
 IN GROUND EFFECT-WHEELS 10 FEET OFF
 MAXIMUM POWER-230 ROTOR RPM
 (APPROXIMATE)

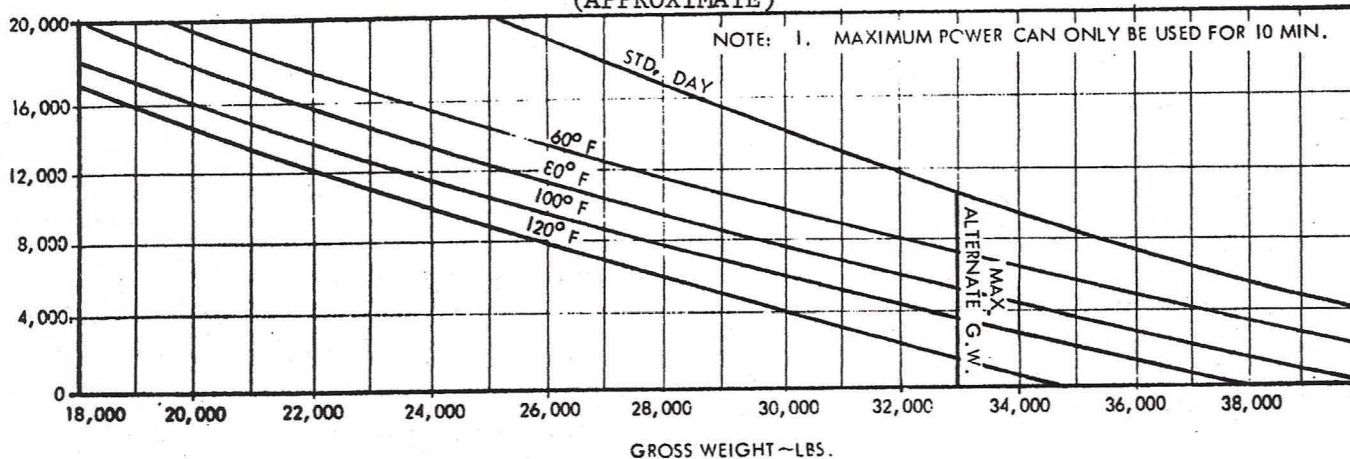

CH-47A WITH T55-L-7 ENGINE
 MISSION RADIUS VS. GROSS WT. FOR VARIOUS PAYLOADS
 WEIGHT EMPTY = 17,132 LBS, FIXED USEFUL LOAD= 462 LBS.

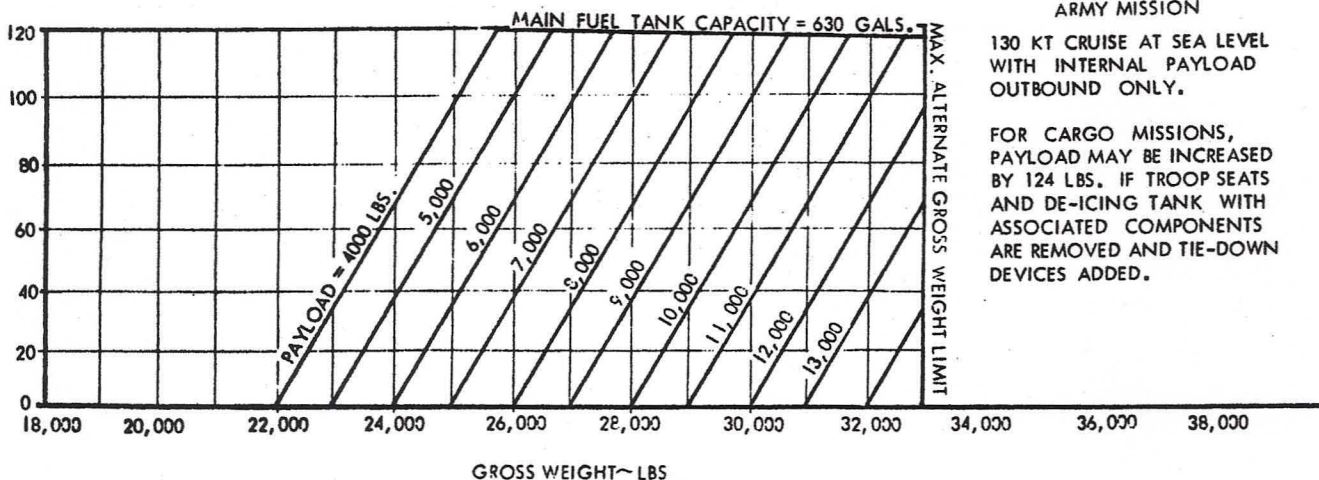

CH-47A WITH T55-L-7 ENGINE
 HOVER CEILING
 OUT OF GROUND EFFECT MAXIMUM POWER
 230 ROTOR RPM

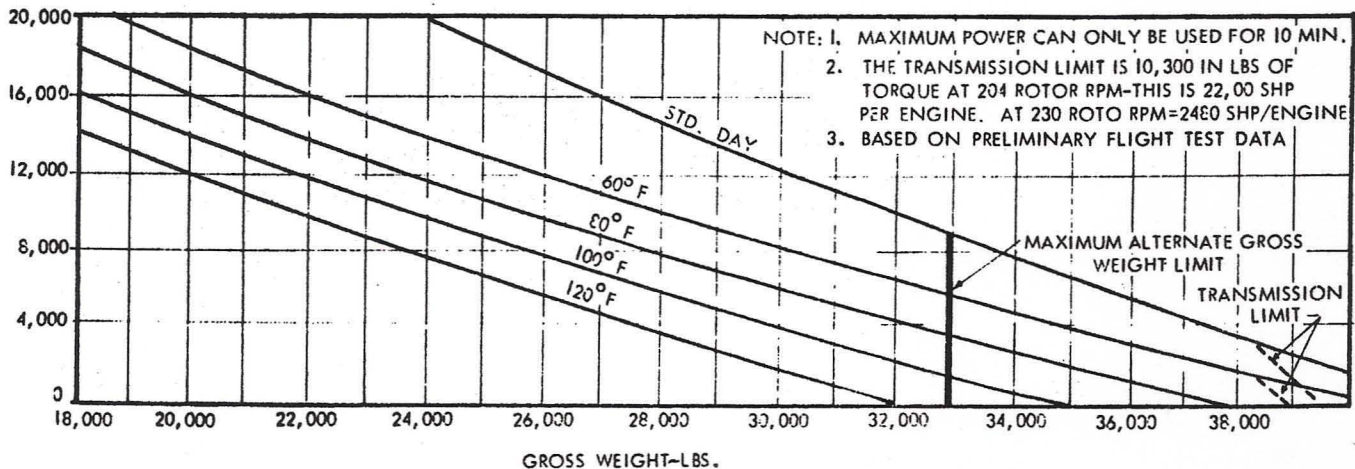

FOR OFFICIAL USE ONLY

SECTION II

DETAILED DEVELOPMENT PLAN

1. Description of End Items: The model CH-47A Helicopter is a 3 ton twin engine, tandem-rotor, medium transport helicopter manufactured by the Vertol Division, Boeing Company. Power is supplied by two (2) Lycoming T55-L-7 gas turbine engines, mounted externally on the aft pylon structure of the fuselage. A changeover from T55-L-5 to T55-L-7 engines was made midway in the FY 62 production run of CH-47A aircraft and is effective on November 1963 helicopters. The engines simultaneously drive two (2) three-bladed rotors through drive shafts and reduction transmissions. The fuselage is of all metal stressed skin construction with an aft cargo loading arrangement. The cockpit is arranged to provide maximum visibility and such instrumentation as required for safe and efficient flight of the helicopter. Dual flight controls are provided. The basic crew consists of a pilot, co-pilot, and a flight engineer. The rear ramp facilitates rapid loading and unloading. The hinged door is lowered to form a ramp, providing 78 inch minimum clearance for loading operations. In flight, the ramp can be left open to permit carrying, internally, any item longer than the cargo compartment. The CH-47 has the provisions for 33 troop seats or 24 standard type litters. Of prime interest is a functional feature, wherein the CH-47 has the capability to carry a variety of tactical missiles or special weapons to dispersed operating sites. As a tandem helicopter with unique longitudinal control characteristics, it is well suited for towing operations. The instrument flight capabilities are enhanced by a dual Stability Augmentation System (SAS). The general operational characteristics and the ease with which maintenance can be performed are considered significant features of the helicopter.

a. Description of sub-systems:

(1) Electrical Systems: Primary electrical power is generated by two 20 KVA, 115/200 volt 400 cycle, self cooled alternating current generators. The secondary electrical power is furnished by two alternating current-to-direct current convertors, rated at 28 volts, 200 amperes each.

(2) Hydraulic System: There are three hydraulic systems in the aircraft, two identical flight control hydraulic systems and a utility hydraulic system.

(a) Both flight control hydraulic systems are 3000 psi. Each is independent, having its own accumulator, reservoir, and pump.

F O R O F F I C I A L U S E O N L Y

(b) The utility hydraulic system is 3000 psi except that pressure for ground operation is 4000 psi in the starting and power supply circuit.

(3) Power plant and related systems: The power plants consist of two (2) Lycoming gas turbine shaft engines in demountable and interchangeable nacelles. T55-L-5 and T55-L-7 engines are presently installed in all CH-47A aircraft. The T55-L-7 engine has performance superior to the L-5 under hot weather conditions. The engine ignition system is powered by 28 volts D/C. Each engine is started by a hydraulic motor which is energized by a hydraulic pump. The pump is driven by a permanently installed gas turbine auxiliary power unit.

(4) The flight control system of the CH-47 is composed of two power boost systems, two electronic stabilization systems, and a linkage system which kinetically mixes and transmits control motions from the cockpit controls to the rotor heads.

(5) Fuel system: Includes two internal, bladder type crash resistant fuel cells of ~~310.0~~ U. S. Gallons capacity each. The fuel tanks are located in pods on each side of the fuselage.

(6) Drive system: Power from the engines is transmitted through right angle gear boxes to a combining box and then by shafting to the forward and aft transmissions.

(7) Rotary wing head is a fully articulated assembly containing horizontal and vertical pins and pitch bearings. The head allows each blade to flap, lead-lag and change pitch.

(8) Rotor blades are built-up around a structural spar with fiberglass skins bonded to aluminum alloy ribs. Laminated stainless steel strips extend the length of the blade trailing edge. A de-icing system is to be included within each blade.

b. See illustration pages 19 - 28 inclusive.

FOR OFFICIAL USE ONLY

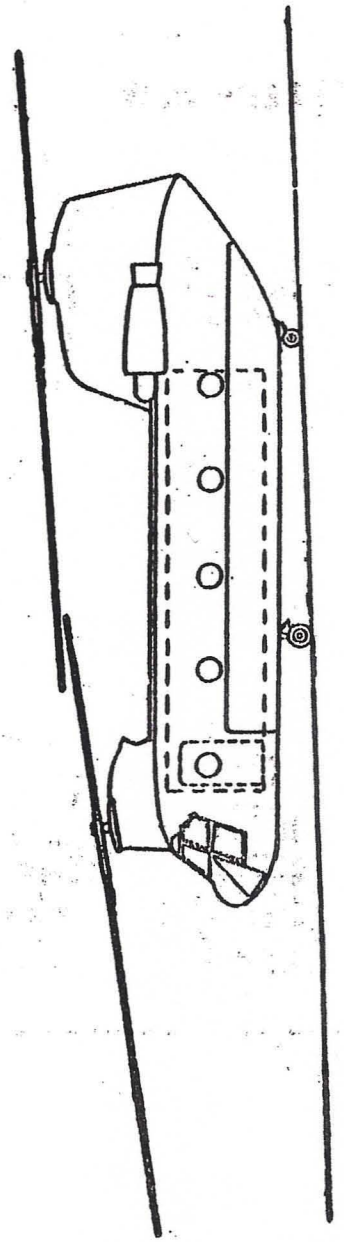
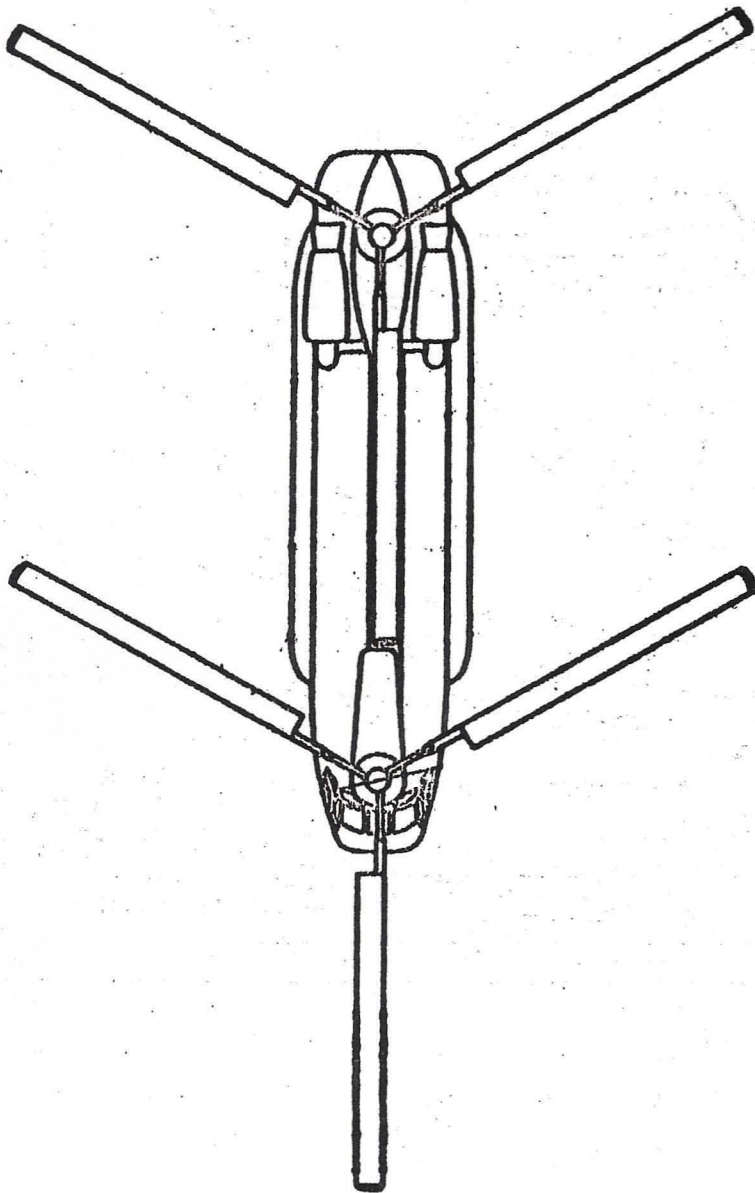

THREE - VIEW

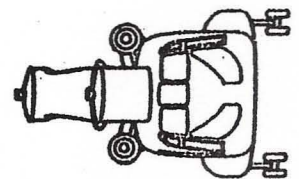

THREE-VIEW

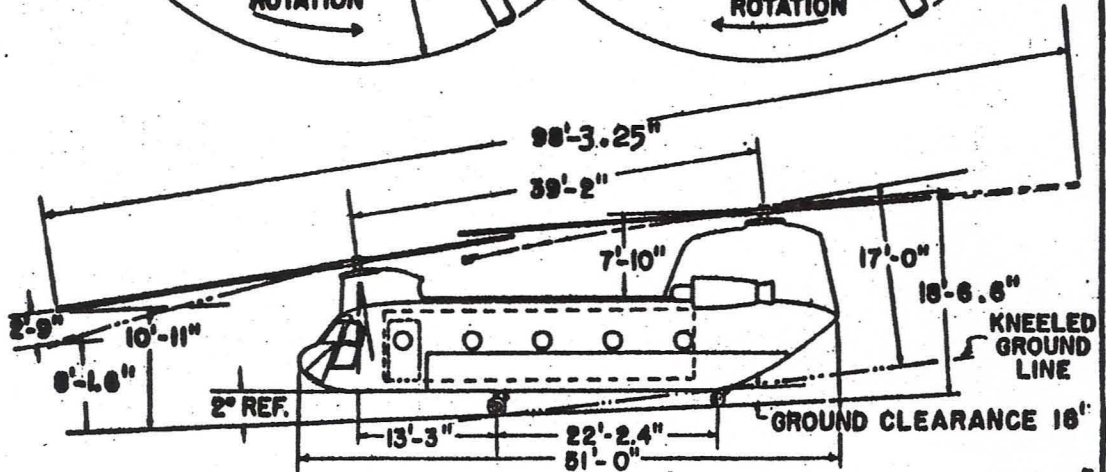
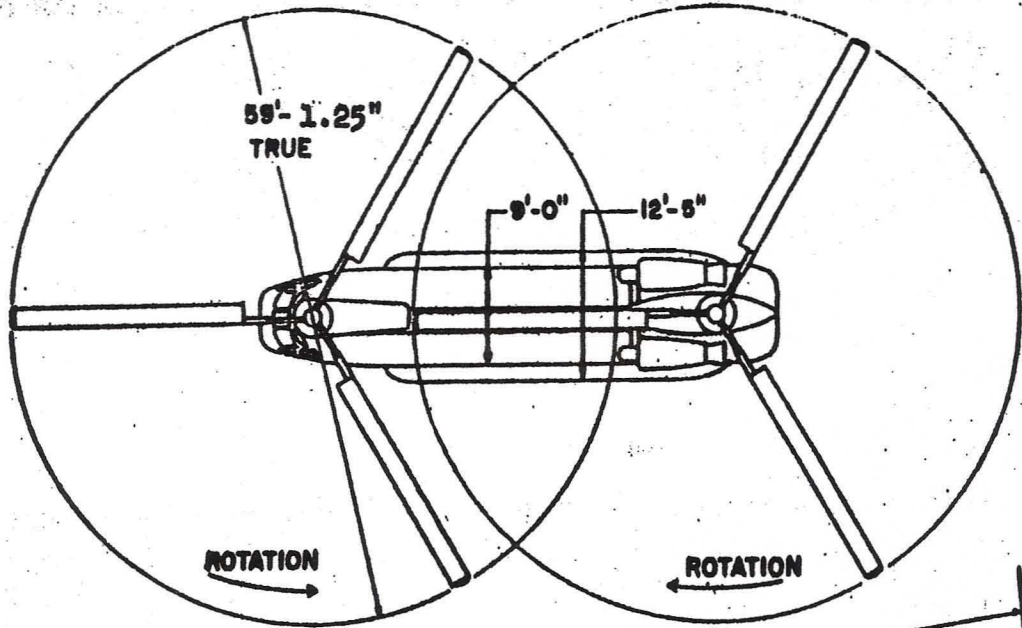

FOR OFFICIAL USE ONLY

AIRFRAME SECTIONS

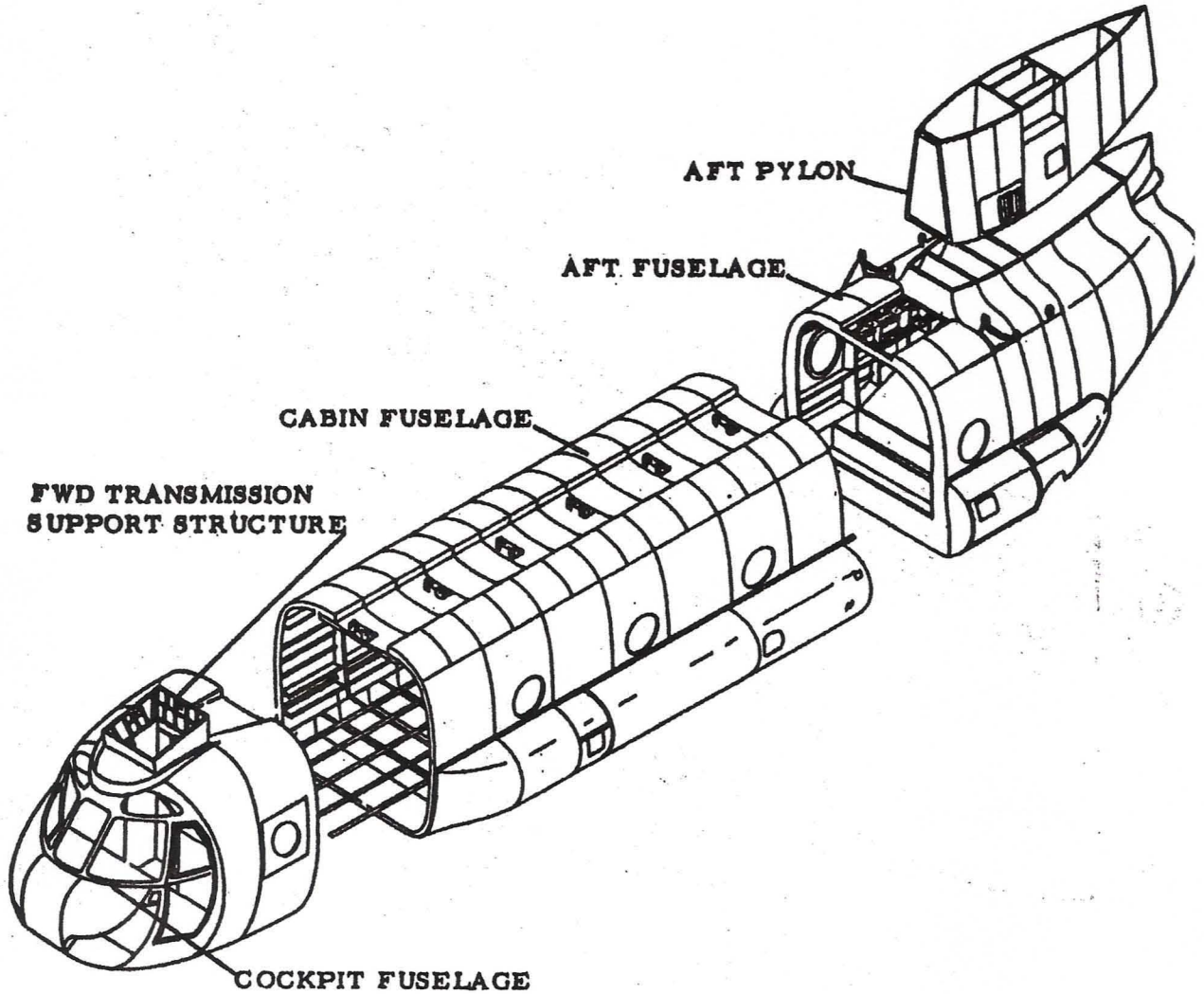

FOR OFFICIAL USE ONLY

DRIVE SYSTEM

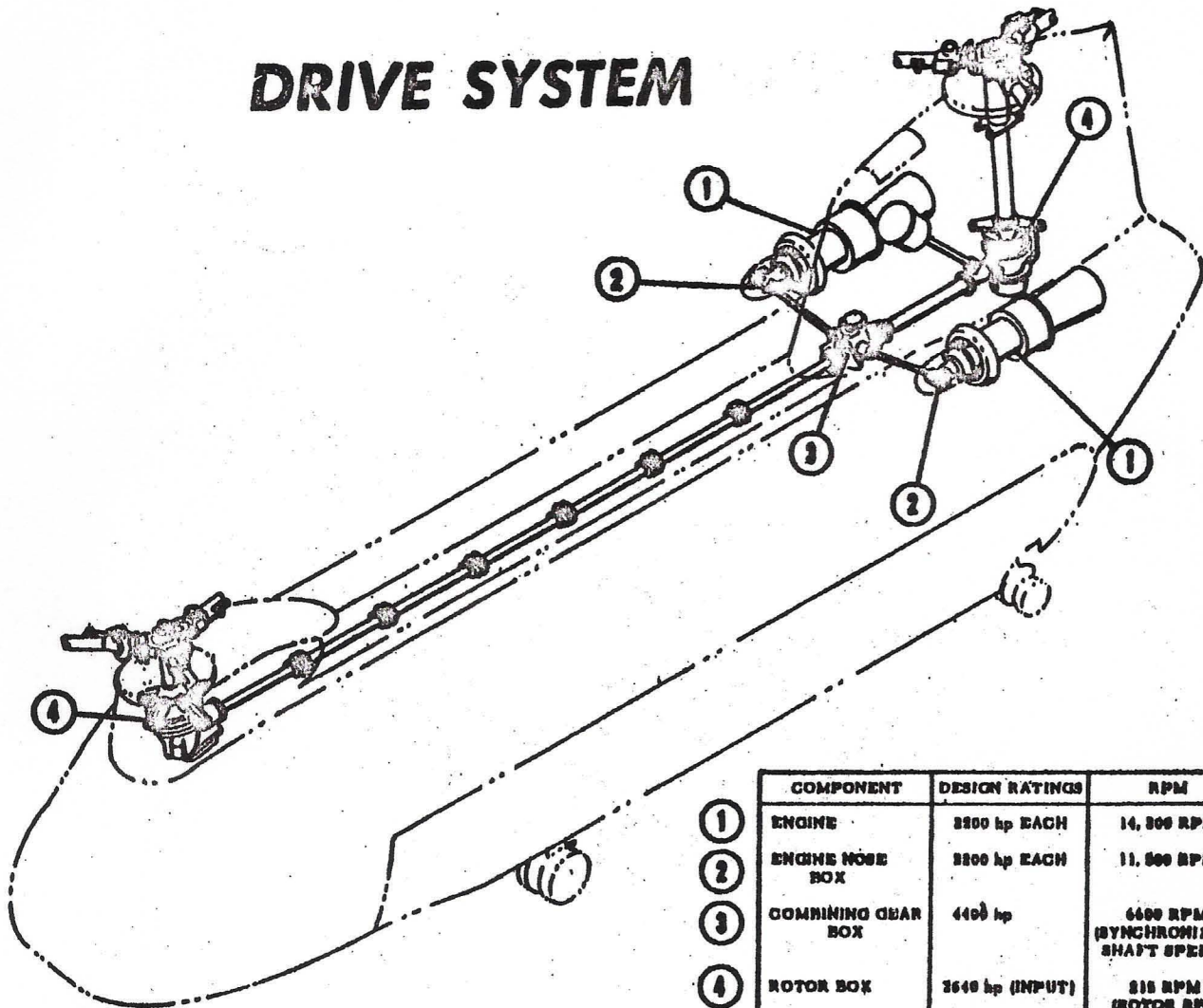

	COMPONENT	DESIGN RATINGS	RPM
①	ENGINE	2200 hp EACH	14,300 RPM
②	ENGINE NOSE BOX	2200 hp EACH	11,000 RPM
③	COMBINING GEAR BOX	4400 hp	6600 RPM (SYNCHRONIZING SHAFT SPEED)
④	ROTOR BOX	2640 hp (INPUT)	215 RPM (ROTOR RPM)

FOR OFFICIAL USE ONLY

ROTOR HUB AND CONTROLS

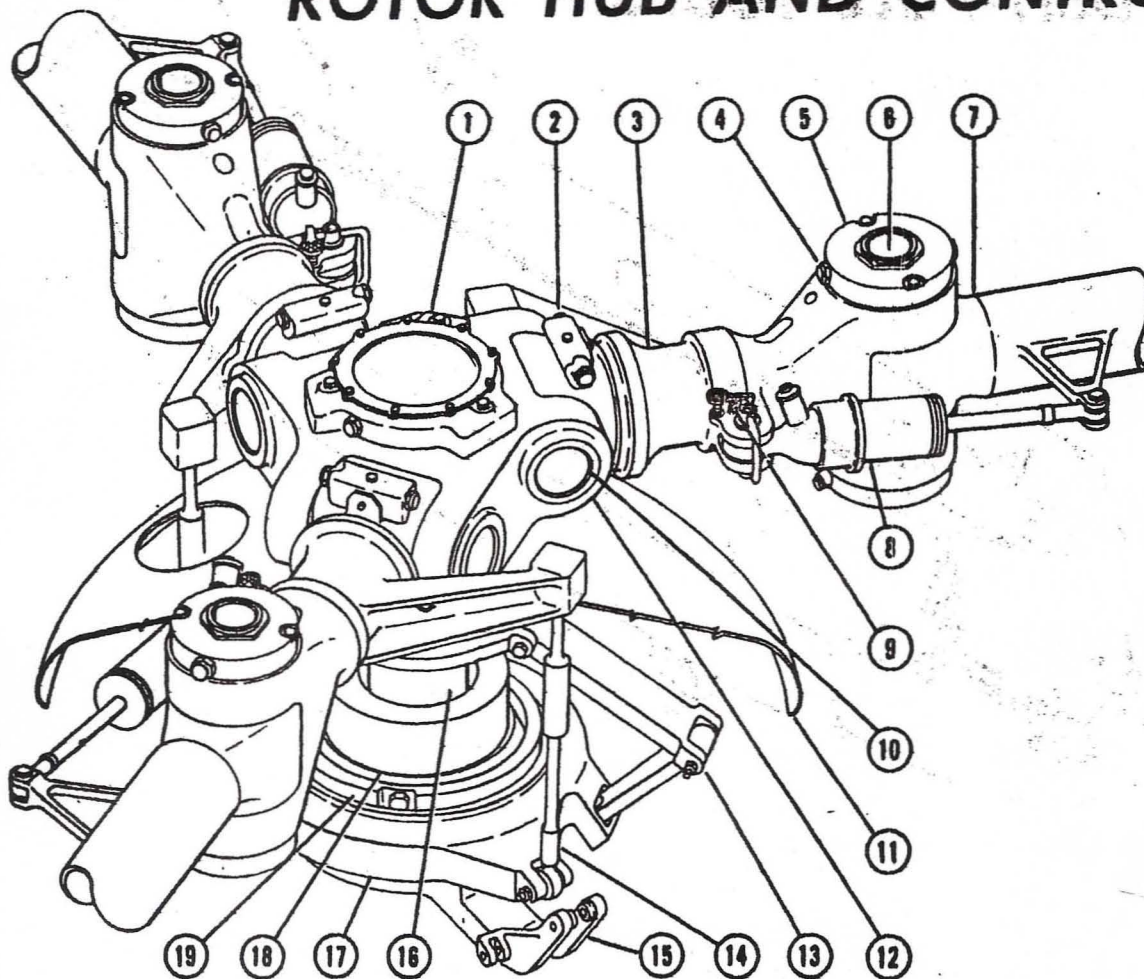

- | | |
|-------------------------------|---------------------------|
| 1 Rotor Hub Reservoir | 11 Rainshield Assembly |
| 2 Pitch Shaft Reservoir | 12 Rotor Hub |
| 3 Pitch Housing and Shaft | 13 Drag Scissors Assembly |
| 4 Sight Gage | 14 Pitch Link Assembly |
| 5 Vertical Pin Oil Reservoir | 15 Lower Swashplate |
| 6 Vertical Hinge Pin | 16 Rotor Drive Shaft |
| 7 Blade Socket | 17 Upper Swashplate |
| 8 Lag Damper | 18 Slider Shaft |
| 9 Lag Damper Quick-Disconnect | 19 Swashplate Reservoir |
| 10 Horizontal Hinge Pin | |

FOR OFFICIAL USE ONLY

PUSH-PULL TUBES

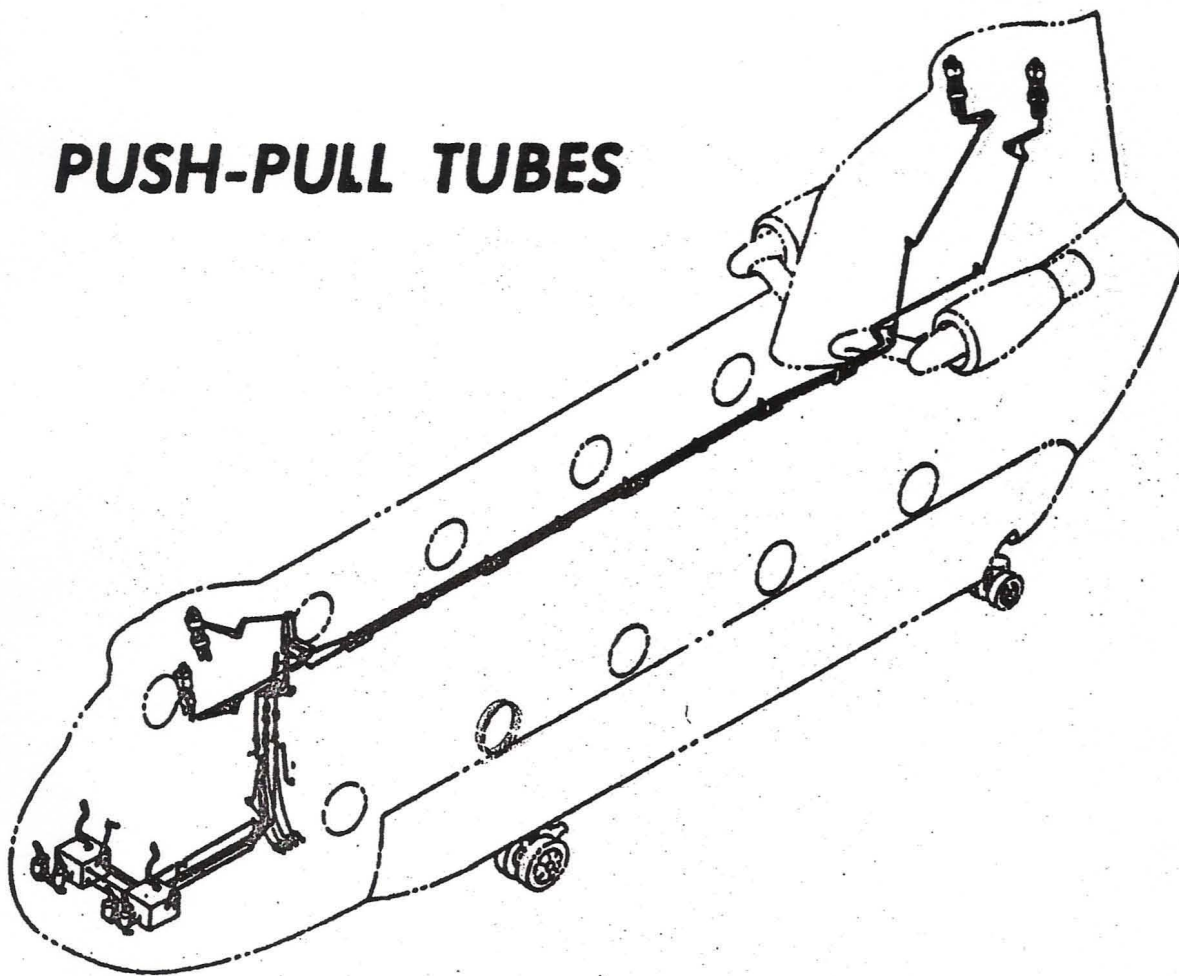

FOR OFFICIAL USE ONLY

CABIN FLOOR

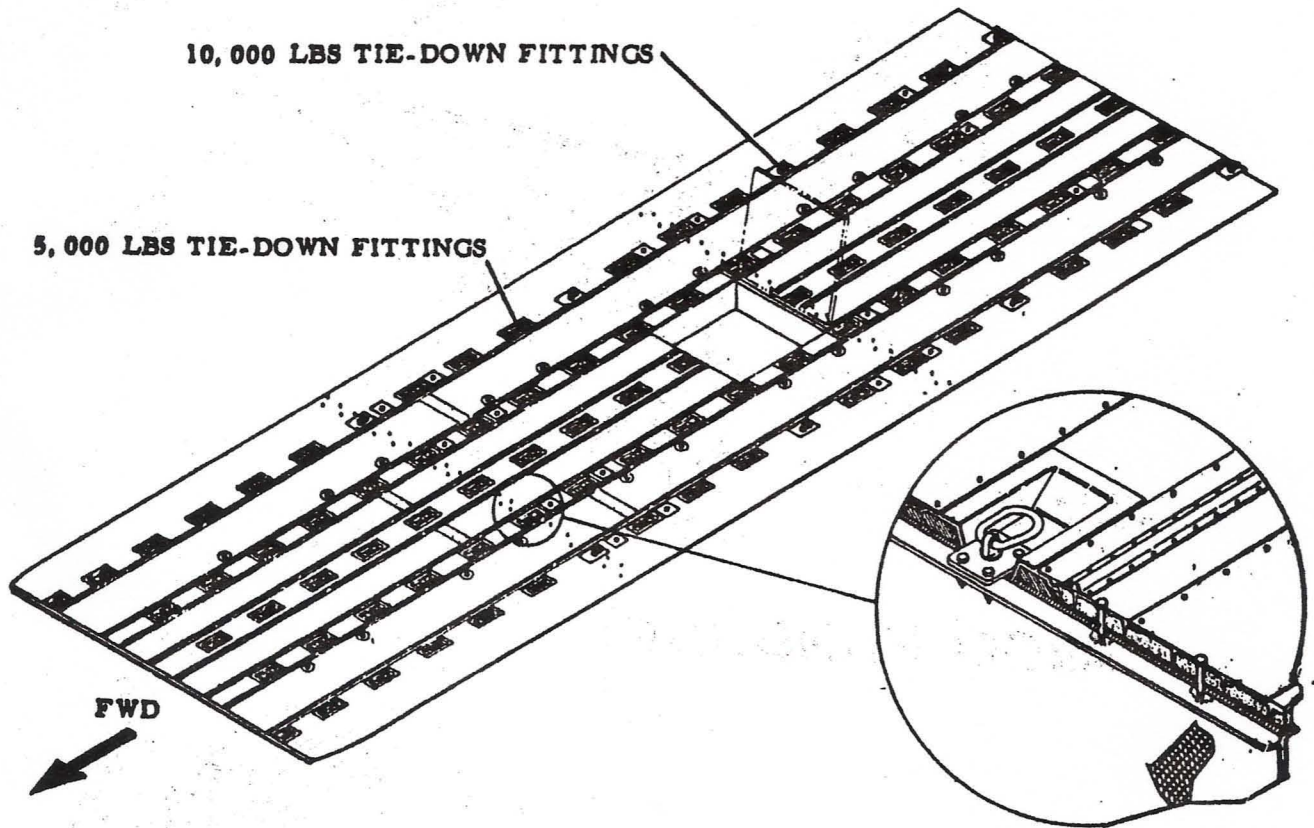

FOR OFFICIAL USE ONLY
25

CARGO HOOK

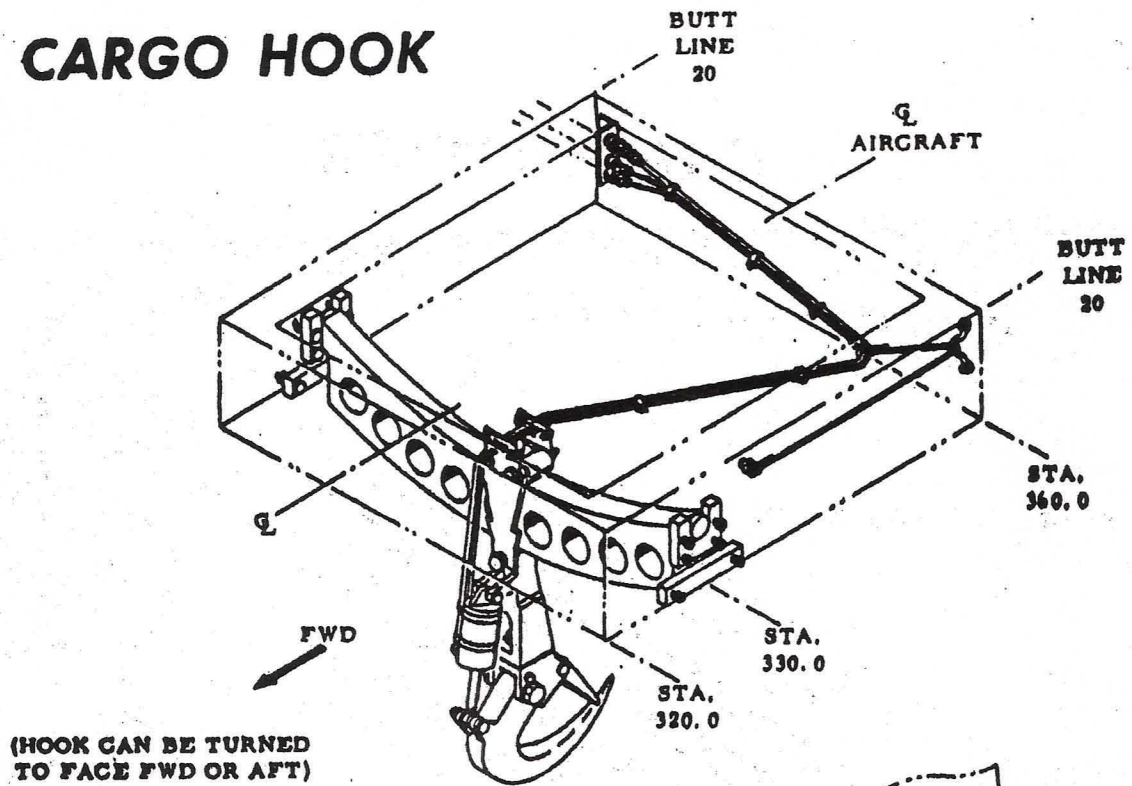

CARGO HANDLING

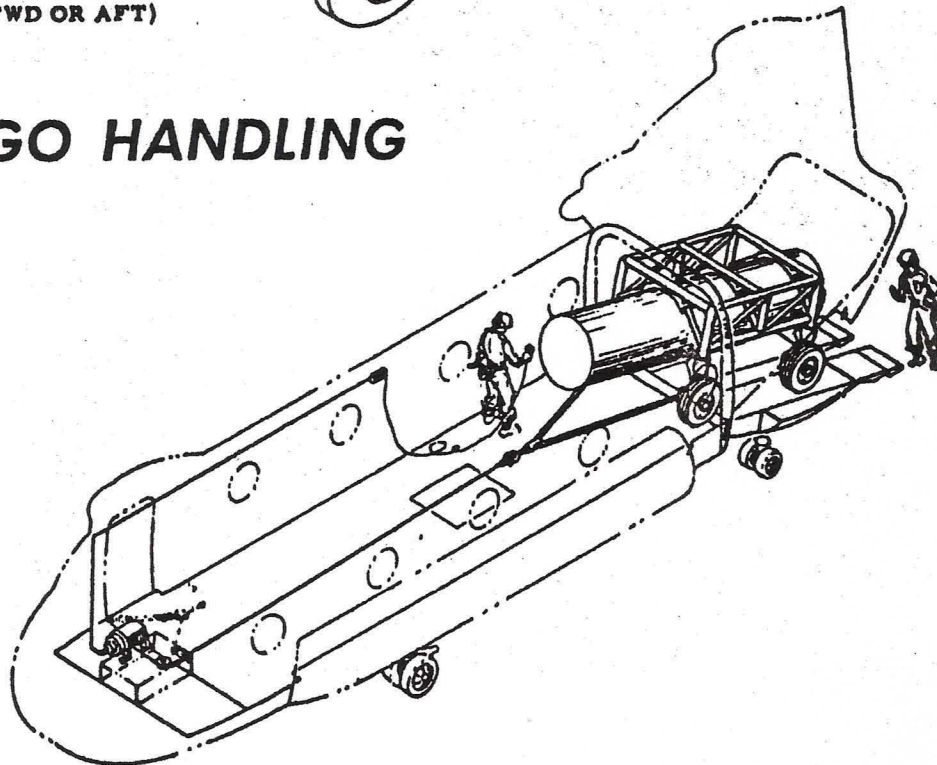

FOR OFFICIAL USE ONLY

RESCUE HOIST

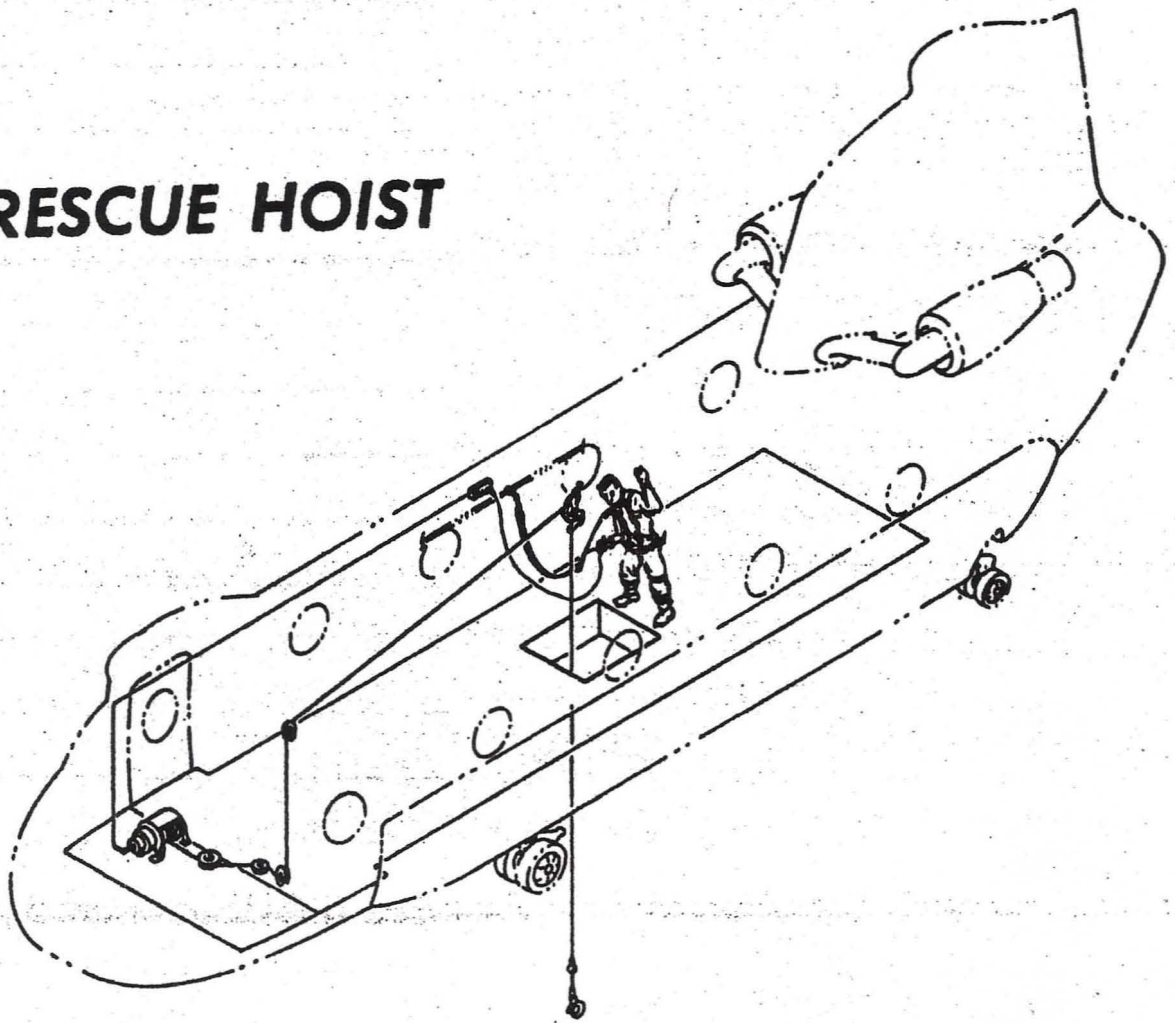

FOR OFFICIAL USE ONLY

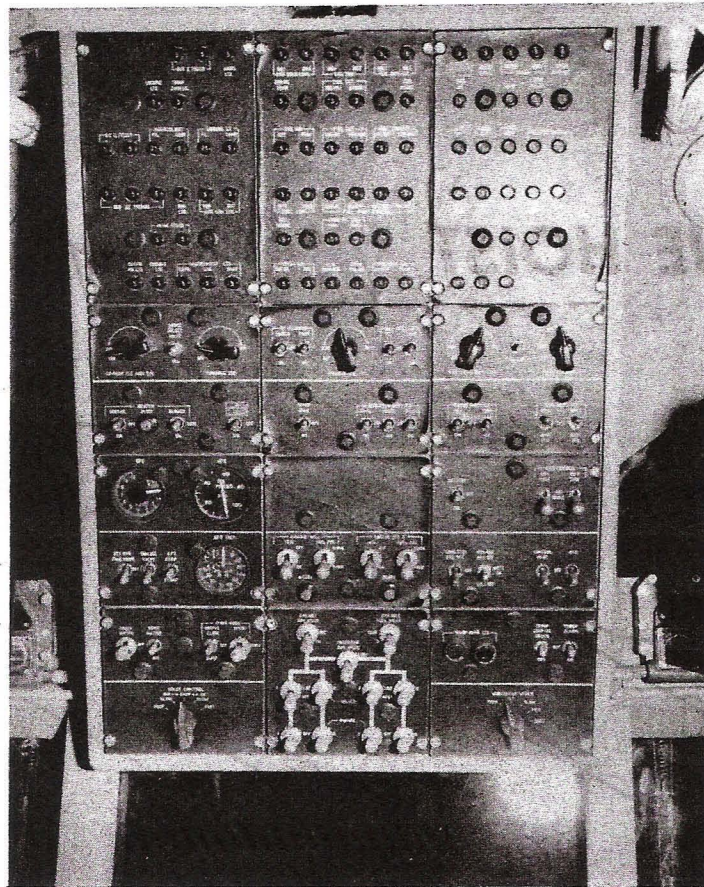

Overhead Panel

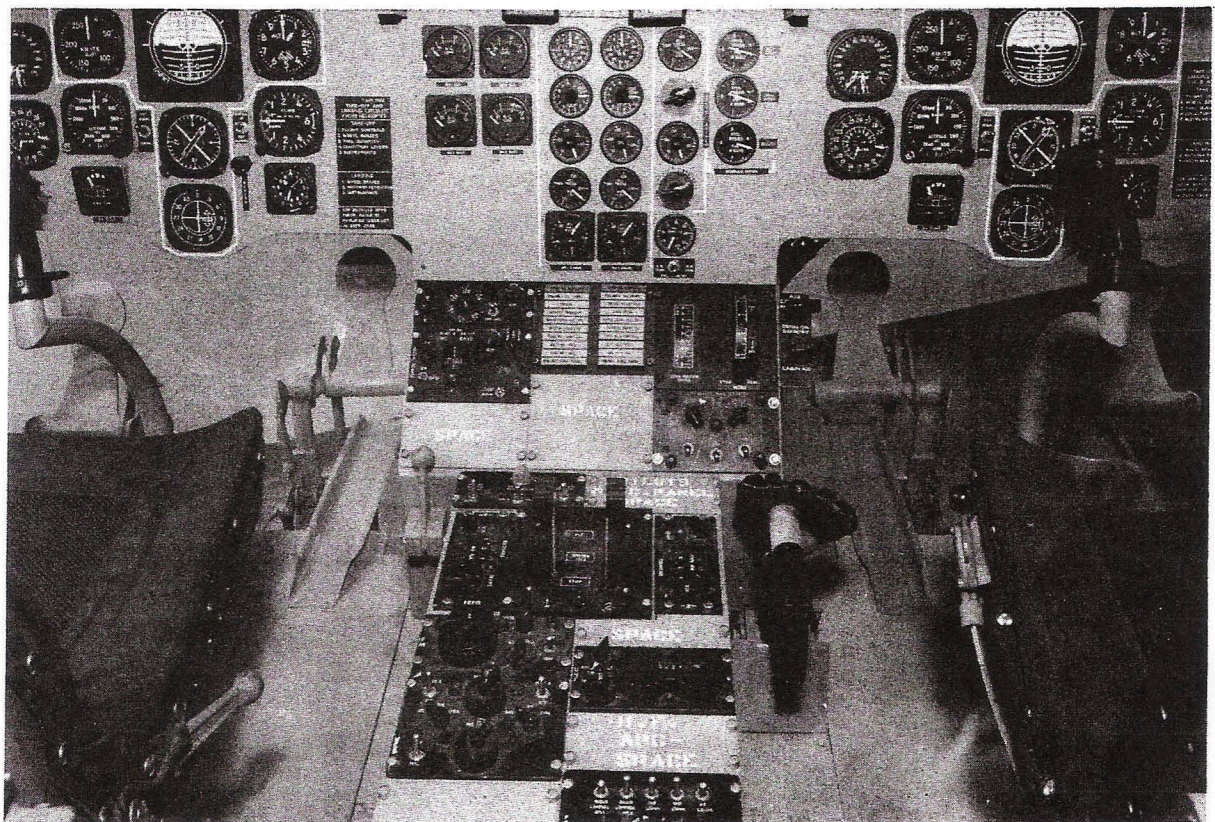

Instrument Panel and Console
FOR OFFICIAL USE ONLY

2. PERFORMANCE CHARACTERISTICS
 WITH T55-L-5 INSTALLED
 (Model Spec 114-X-201)

	MISSION I	MISSION II	MISSION III	MISSION IV
Gross Weight	25,500	27,500	33,000	33,000
Weight Empty	16,930	16,930	17,085	16,561
Payload (Estimated) - Outbound/Inbound	4060/2030	6012/3006	14/245/0	--
Payload (Guaranteed) - Outbound/Inbound	4000*/2000*	6000*/3000*	--	--
Radius of Action	100*	100*	20	--
Ferry Range (with auxiliary tankage)	--	--	--	917
Mission Cruise Altitude	S. L.	S. L.	S. L.	5000/10,000
V max @ S. L. & Military Power	153	152	132	146
V max @ S. L. & Normal Power	145	143	121	136
V max @ 5000 Ft. & Normal Power	143	140	116	125
Hover Ceiling (OGE) & Mil Power, Std Atmos	11,650	9,000	3,250	3,250
Hover Ceiling (OGE) & Mil Power @ 95°F	6,000*	--	--	--
Hover Ceiling (OGE) & Mil Power @ 100°F	--	3,000*	--	--
Hover Ceiling (IGE) - (10 ft. off) @ Mil Power, Std Atmos	14,500	12,000	5,500	5,500
Service Ceiling @ Normal Power	18,600	16,400	10,700	10,700
Service Ceiling @ Mil Power, One Engine Out	5,800*	2,600	--	--
R/C Maximum @ Mil Power @ S. L.	2,696	2,404	1,662	1,662
Mission Cruise Speed - Average	130*	130	**100/130	120/126

* Values Indicate Guaranteed Performance

** Outbound/Inbound

2. PERFORMANCE CHARACTERISTICS

WITH T55-L-7 INSTALLED

(Model Spec 114-X-301 dated 1 Aug 1963)

	UNITS	MISSION I	MISSION II	MISSION III
Gross Weight	LB	28,200	33,000	33,000
Weight Empty	LB	17,132	17,312	16,759
Payload (Estimated) - Outbound/Inbound	LB	--	13,600/0	--
Payload (Guaranteed) - Outbound/Inbound	LB	6000*/3000*	--	--
Radius of Action	N. Mi.	100*	20	--
Ferry Range (with auxiliary tankage)	N. Mi.	--	--	862
Mission Cruise Altitude	Ft.	S.L.	S.L.	5000/10,000
V max @ S. L. & Military Power	Knots	157	137	151
V max @ S. L. & Normal Power	Knots	151	131	146
V max @ 5000 Ft. & Normal Power	Knots	147	124	136
Hover Ceiling (OGE) & Mil Power, Std Atmos	Ft.	14,575	8,350	8,350
Hover Ceiling (OGE) & Mil Power @ 95°F	Ft.	--	--	--
Hover Ceiling (OGE) & Mil Power @ 100°F	Ft.	3,000*	--	--
Hover Ceiling (IGE) - (10 ft. off) @ Mil Power, Std Atmos	Ft.	17,200	13,300	11,300
Service Ceiling @ Normal Power	Ft.	21,300	15,350	15,350
Service Ceiling @ Mil Power, One Engine Out	Ft.	7,200	--	--
R/C Maximum @ Mil Power @ S. L.	FPM	3,275	2,340	2,340
Mission Cruise Speed - Average	Knots	**130/130	**100/130	125

* Values Indicate Guaranteed Performance

** Outbound/Inbound

3. Status of Military Characteristic (MC) Kits:

a. Winterization - A winterization kit which consisted of insulation and an auxillary heater was tested during the climatic hanger program. Testing indicated that this configuration was inadequate at extreme low temperatures. The kit was subsequently redesigned to include improved insulation blankets and a larger heater. The new kit is now being evaluated during the Arctic testing; the final configuration will depend upon the results of these tests.

b. Litter - Delivered with #6 and #8 aircraft. Service testing was completed in November 1963.

c. Tow - Delivered with #6 and #8 aircraft. CDC indicates there is no requirement for towing. DA direction has not been received.

d. Extended Ferry Range and Liquid Cargo Tankage - Same tanks - on contract. This kit will be modified to provide the Chinook the capability for use as an aircraft tanker for aircraft refueling.

e. Self-Sealing Fuel Tanks - Contractor preparing ECP for FY 61 and FY 62 aircraft. FY 63 and FY 64 model spec contain this provision.

f. Suppressive Fire - Awaiting definition of requirement from CDC.

g. Skis - Three sets of skis on contract will be tested in Army Arctic tests during winter CY 63 - 64.

h. Static Electricity Discharge - a final prototype installation of a 150 micro amp discharger will be installed for Army Arctic Test. CY 63 - 64.

i. Amphibious Landing - Contractor submitting ECP for retrofit of FY 61 and FY 62 aircraft. Will be permanent installation on FY 63 and FY 64 aircraft.

j. Aft Landing Gear Kneeling Kit - Delivered with #10 aircraft. Test being conducted at Ft. Rucker.

k. Infrared Radiation Suppression - Prototype testing is planned for Jan 1964 at Edwards Air Force Base.

4. Schedule of Development including progress to date is shown on Master Phasing and Test Schedule Charts pages 33 through 37.

5. RD Milestones

- a. Issue Requests for Proposals to Industry for Bid - June 1958
- b. Award RDT&E Letter Contract - May 1959
- c. Initiation of Design - July 1959
- d. Type Classification Limited Production - July 1959

F O R O F F I C I A L U S E O N L Y

- e. Award RDT&E Contract - June 1960
 - f. Delivery of First Army Helicopter (No. 8) - June 1962
 - g. Complete Contractor Technical Compliance Inspection - July 1962
 - h. Type classified as Standard "A" - 25 Oct 63
6. The Five Part Manual publications plan for the CH-47 is shown on page 38.

7. Government Facilities Available:

a. Wright-Patterson Air Force Base:

Aeronautical Systems Division (ASD)

b. Edwards Air Force Base

(1) AFFTC

(2) ATA

c. Eglin Air Force Base

Climatic Test Hangar

d. Fort Rucker

Aviation Test Board

e. Fort Bragg

U. S. Army Airbourne, Electronics & Special Warfare Board

f. Fort Greely

Arctic Test Board

8. Construction Requirements: MIPR R61-107, dated 7 October 1960, was submitted to the Navy for construction of a rotor whirl test tower. The MIPR brought about the awarding of contract NOW61-0778-u, dated 17 May 1961 for support of the CH-47 program. The total sum of the MIPR was \$569,687. This tower has been completed. Tracking of production rotor blades began in March 1963.

FOR OFFICIAL USE ONLY

TECHNICAL DEVELOPMENT PLAN

Date

1 January 1964

Reports Control Symbol
CSCRD-21(RI)

Project Number

1-R-1-79191-D-685

Title

CH-47A MASTER PHASING CHART, PART 1

Schedule

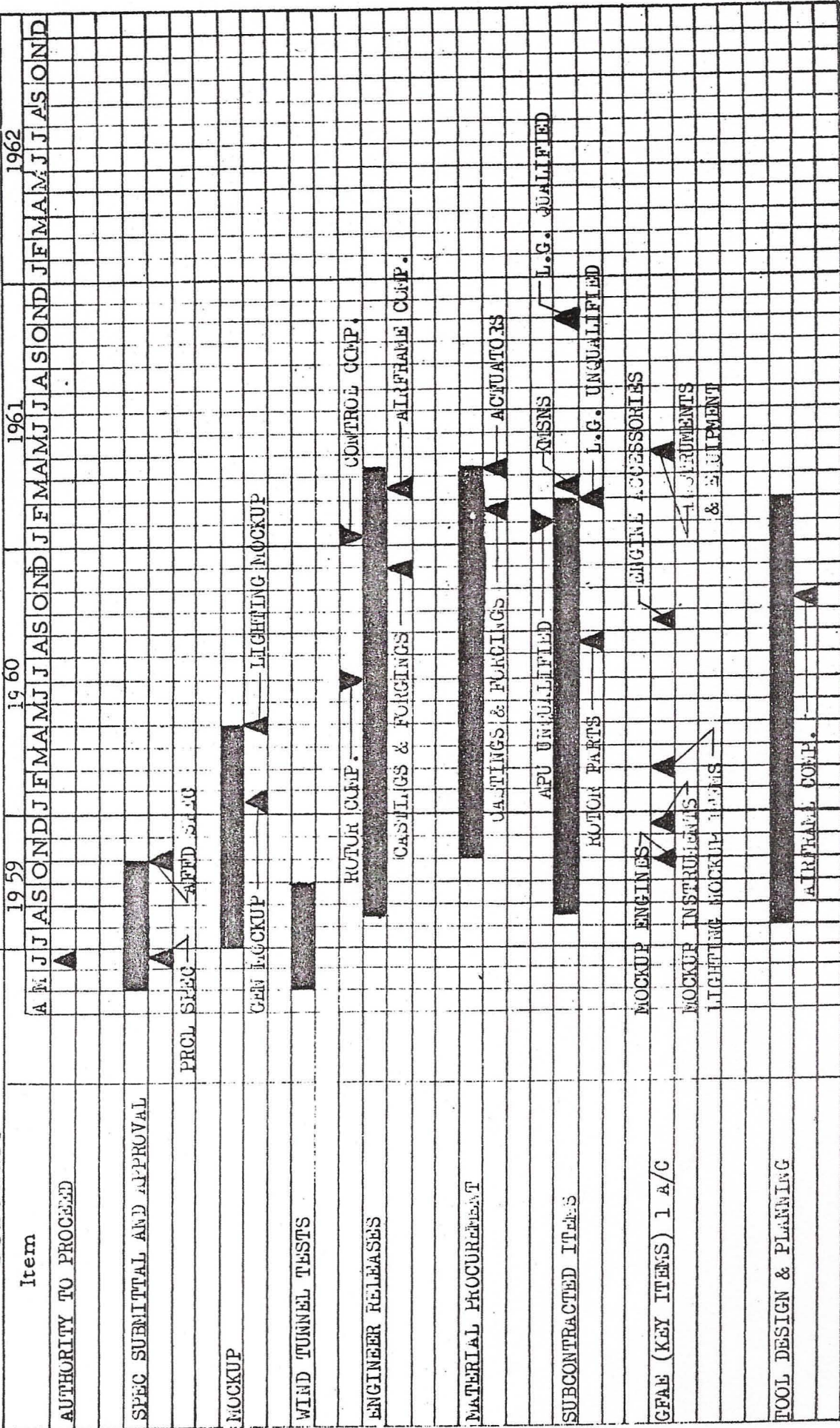

TECHNICAL DEVELOPMENT PLAN

Reports Control Symbol
CSCRD-21 (RI)

Date
1 January 1964

Project Number
1-R-1-79191-D-685

Title
CH-47A MASTER PHASING CHART, PART 2

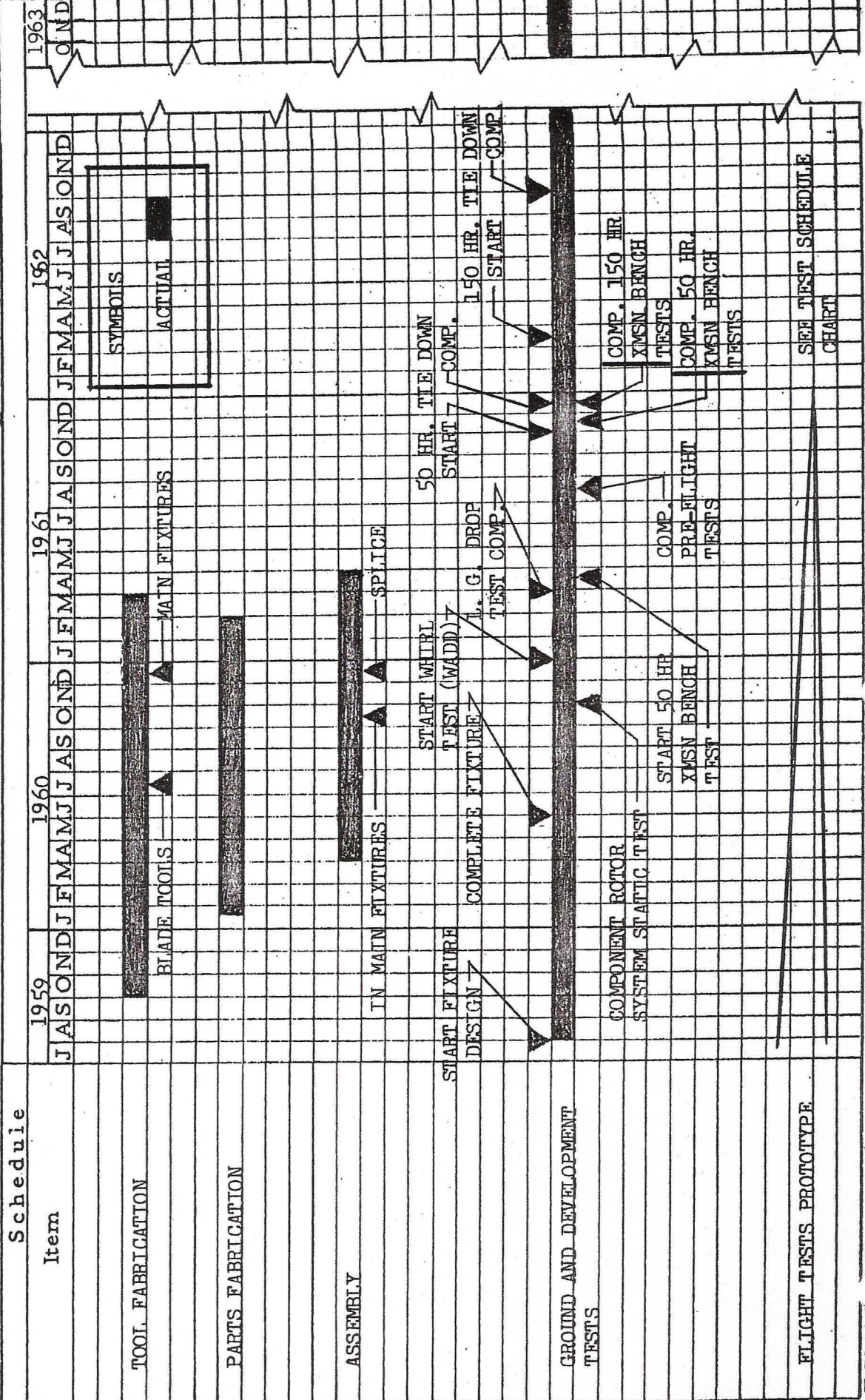

TECHNICAL DEVELOPMENT PLAN

Date
1 January 1964

Reports Control Symbol
CSCRD-2I(RL)

Project Number
1-R-1-79191-D-685

CH-47A MASTER PHASING CHART, PART 3

Schedule

Item	1960			1961			1962			1963								
	J	F	M	A	M	J	J	F	M	A	M	J	J	F	M	A	M	J
PHASE I LIST																		
SUBMITTED																		
PRELIM. REVIEW																		
PHASE II LIST SUBMITTED																		
REPAIR PARTS (SPARES)																		
PRELIM. MEETING																		
SUBMIT LIST																		
GROUND SUPPORT EQUIPMENT																		

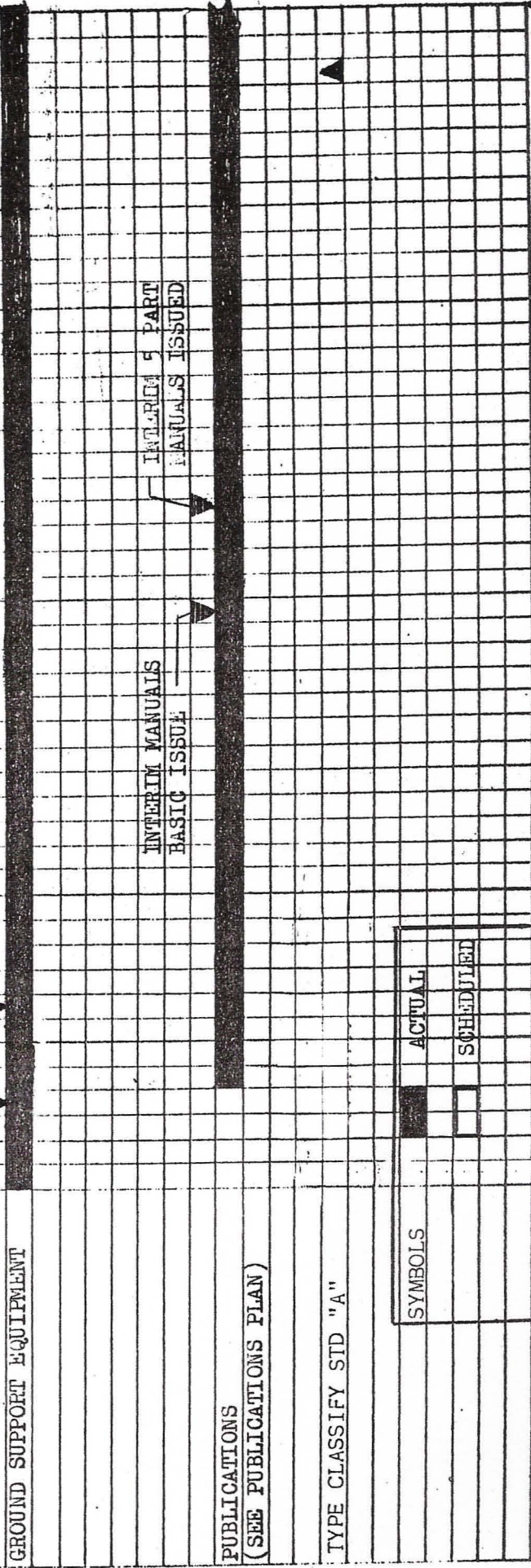

TECHNICAL DEVELOPMENT PLAN

Date

1 January 1964

Reports Control Symbol
CSCRD-21 (R1)

Title

Project Number

CH-47A TEST SCHEDULE

CATEGORY II & III

1-R-1-79191-D-685

Schedule

Item	A/C No.	1962												1963												1964												1965											
		M	J	J	A	S	O	N	D	J	F	M	A	M	J	J	A	S	O	N	D	J	F	M	A	M	J	J	A	S	O	N	D	J	F	M	A	M	J	J	A	S	O	N	D				
CATEGORY II - AIR FORCE & ARMY		EGLIN ✓ VERTOL ✓												EGLIN ✓ / WPAFB ✓												ADVERSE WEATHER ✓ / WPAFB ✓																							
CLIMATIC TEST	4	[REDACTED]												[REDACTED]												[REDACTED]												[REDACTED]											
PERFORMANCE	6	[REDACTED]												EDWARDS ✓												[REDACTED]												[REDACTED]											
STABILITY	7	[REDACTED]												VERTOL ✓												[REDACTED]												[REDACTED]											
ARCTIC TEST - AIR FORCE	4	[REDACTED]												[REDACTED]												[REDACTED]												[REDACTED]											
ARCTIC TEST - ARMY	33	[REDACTED]												ALASKA ✓												[REDACTED]												[REDACTED]											
CATEGORY III - ARMY		[REDACTED]												[REDACTED]												DESERT ✓ / HIGH ELEVATION ✓												[REDACTED]											
PHASE "E" AVN TEST BD	8	[REDACTED]												[REDACTED]												[REDACTED]												[REDACTED]											
PHASE "F" AVN TEST BD	9	ORLANDO ✓												[REDACTED]												[REDACTED]												[REDACTED]											
	10	[REDACTED]												[REDACTED]												[REDACTED]												[REDACTED]											
	17	[REDACTED]												[REDACTED]												REPLACED BY A/C 17												[REDACTED]											
		[REDACTED]												[REDACTED]												[REDACTED]												ACCELERATED ✓											
		[REDACTED]												[REDACTED]												[REDACTED]												NON-ACCELERATED											

TECHNICAL DEVELOPMENT PLAN

Reports Control Symbol
CSCRD-21(81)

Date
1 January 1964

Title
CH-47A PUBLICATION PLAN

Project Number
1-R-1-79191-D-685

Schedule

Item	CY 19 61			CY 19 62			CY 19 63			CY 1964							
	J	A	S	O	N	D	J	F	M	A	M	J	J	A	S	O	N
FLIGHT TEST SCHEDULE as applicable to Publication Plan																	
CONTRACT YEAR FY 60																	
CONTRACT YEAR FY 61																	
CONTRACT YEAR FY 62																	
SYMBOLS																	
INTERIM MANUAL TAG AUTHENTICATION PLAN																	
DISTRIBUTION																	
TAG PRINT																	
REVIEW																	
DATA CUT OFF																	

FOR OFFICIAL USE ONLY

SECTION III

RELIABILITY PROGRAM AND MAINTAINABILITY PROGRAM

1. Operational Information That Affects Reliability and Maintainability Design.

a. Planned deployment.

This aircraft will be used on combat operations to increase the mobility of the Army in the field. It will be used as a means of transport for personnel, weapons, and cargo to obtain this objective. This aircraft will be organic to Army helicopter units, organic aviation units at division and corps level, and may become a common user item of organic transportation in other combat units.

b. Reaction time required:
90 minutes (estimated)

c. Mission duration requirement for each type mission:

Mission I	- 130K cruise for 100NM radius	-- 2 hours
Mission II	- 130K cruise for 20NM radius	-- $\frac{1}{2}$ hour
Mission III	- 124K cruise for 862NM radius	-- 7 hours

d. Turnaround time required (no repair):
30 minutes (estimated)

e. Overall reliability for each type mission:
95% (estimated)

f. Availability or combat ready rate:
75% (estimated)

g. Maintenance and operating environmental conditions:
Environment:

- (1) Temperature: -65°F to 135°F
- (2) Altitude: Sea level to 23,700 feet
- (3) Design gust velocity: 50 -0.5 ft/sec
- (4) Ice, snow, sand, dust, insects, and fungus

Support:

Organizational, field, heavy field, and depot

h. Planned utilization rate:
50 flying hours per month per aircraft

F O R O F F I C I A L U S E O N L Y

2. Planning Information Needed for Reliability and Maintainability Design.

a. Mean time to return to service goals:

It is estimated that 17.5 maintenance hours will be required for each flying hour.

b. Reliability after storage goals:

It is estimated that reliability will be 85% after 2 years storage.

c. Minimum allowable time between scheduled maintenance:

Daily. Scheduled maintenance is also performed on 25 and 100 flying-hour intervals.

d. Test and checkout philosophy:

The aircraft is designed for maximum simplicity and ease of maintenance, servicing, and production. Operator checks, tests, and assembly of components and maintenance as may be required by using troops, must be capable of being performed by user school-trained personnel. The CH-47 is self sufficient in the field. This is provided by the integral Auxillary Power Plant (APP) for electrical and hydraulic power and integral work platforms for maintenance.

e. Echelons of maintenance and maintenance concept:

First Echelon - The operator and/or ground crew performs routine inspections and reports any malfunction to a higher echelon.

Second Echelon - Performs preventative maintenance on the helicopter, such as visual inspection, cleaning, and tightening. Makes external adjustments on equipment and performs operational checks using the appropriate test equipment. Performs replacement of easily removed assemblies and component parts. Removes defective equipment for evacuation to a higher echelon and installs replacement equipment.

Third Echelon - Performs field maintenance on equipment for return to user. Isolates causes of equipment malfunction and replaces accessible parts. Performs operational check, and adjusts equipment after repair.

Fourth Echelon: Performs heavy maintenance and minor component overhaul on equipment for return to user. Performs intricate bench testing, calibration, alignment, adjustment, and repairs on equipment.

FOR OFFICIAL USE ONLY

Fifth Echelon - Performs depot maintenance on major components for return to depot stock. Fabricates or procures parts not stocked in the supply system. Equipment may be returned to a manufacturer for repair at the depot's discretion, based on economic feasibility and the depot's workload.

f. Maintenance and crew personnel and training allocated for support of this program:

(1) Service School training courses (transition) for the airframe and engine were initiated in June 1963, and are continuing on a scheduled and required basis. Service school training courses for the electronic equipment was initiated in July 1963, and is continuing on a scheduled and required basis.

(2) U. S. Army instructor pilots were given transition pilot training at Vertol Division. This was accomplished by contract and has been completed. Transition pilot training is being conducted on a continuing and required basis at the Aviation School, Ft. Rucker, Ala.

(3) Peculiar requirements for MOS's are being developed by the Aviation School, Fort Rucker, Alabama, and the Transportation Training Command, Fort Eustis, Virginia. These MOS's are presently being coordinated with the appropriate agencies.

(4) Significant Training Aids - Training aids have been procured and delivered for the following:

(a) Composite powertrain, flight control and hydraulic systems trainer.

(b) Stability augmentation system and automatic stabilization equipment trainer.

(c) Fuel systems trainer.

(d) Utility Hydraulic Systems trainer (wet panel).

(e) Electrical systems trainer.

(f) Utility hydraulic systems trainer (wet tubular framework).

(5) Training Literature - Training literature being utilized by the Army Service Schools consists of the "Training Manual" developed by Vertol and Lycoming for their contract training courses. These "Training Manuals" are revised to reflect the echelon system of maintenance support.

F O R O F F I C I A L U S E O N L Y

3. Plans for a Reliability Program Outlining How Reliability Will be Achieved.

a. Determination of equipment environmental conditions -- Reliability of the aircraft, subsystem, parts, etc., under extreme environmental conditions will be determined from results of the following tests:

(1) Extreme temperature tests (-65° to +135°F)

Components such as the T55 engine, T62 APU and starters are subjected to test all running over the entire temperature range.

The complete aircraft has been tested twice in the Climate Hanger at Eglin AF Base over the entire temperature range.

Hot weather user tests of the aircraft were conducted in the desert at Yuma, Arizona, in the summer of 1963.

Cold weather tests on the aircraft are being conducted in Alaska in the winter of 1963, by the Air Force and by the Arctic Test Board.

(2) High density altitude tests

The T55 engines and T62 APU are currently being tested to high density altitudes in test cells.

The CH-47 aircraft was tested at high density altitude by the Aviation Test Board in the summer of 1963, and is currently undergoing other high density altitude testing at Bishop, California, which is being conducted by the Air Force.

Reliability of the aircraft under environmental conditions which simulate actual field usage is being determined by the Aviation Test Board in their Phase "E" testing which is currently being conducted at Ft. Rucker, Alabama.

b. Periodic specification review:

The model specification by which the aircraft are procured is reviewed annually and updated prior to award of contract for following year production.

c. Reliability apportionment and prediction:

Reliability of the CH-47 is apportioned and predicted from a review of all EIRs and all component disassembly forms submitted for a given period of CH-47 operation. It was provided to AMCRD-SS per RCS CSCRD-73 on 8 Oct 63, and will be determined periodically on a continuing basis.

F O R O F F I C I A L U S E O N L Y

	<u>Mission</u> <u>Reliability</u>	<u>Prediction</u> <u>(1 Jan 65)</u>	<u>Status</u> <u>1 Jan 64</u>
Overall System	0.95	0.870	0.832
Subsystem: Airframe	0.99	0.990	0.985
Propulsion	0.99	0.985	0.985
Power Train	0.99	0.915	0.890
Controls	0.99	0.985	0.984
Electrical	0.99	0.990	0.985

d. Reliability design reviews:

Reliability of design is a continuous process by the contractor during the development, design and production cycle. It is monitored by the developing agency (Air Force) and plant cognizant agency (Bureau of Naval Weapons (BuWepps)) through all development testing.

e. Human error analysis and prediction:

The design of the CH-47 was closely monitored by contractor personnel who were intimately familiar with the capabilities and limitations of servicing, maintenance, and operational personnel so that human errors which would have adverse effects on the helicopter would be minimized. Operating and test agencies report conditions which they determine are most susceptible to human error and these are rectified when received.

f. Reliability test and demonstration:

(1) Initial reliability is demonstrated by the contractor through bench testing of components and tie-down testing of the complete aircraft. Additional reliability demonstration is achieved by the contractor and Air Force engineering tests and Army user tests. Final demonstration of reliability is to be accomplished by the U. S. Army Aviation Test Board, Fort Rucker, Alabama, during the 6800 hours accelerated logistical evaluation tests.

(2) A Product Improvement Program is now in effect to verify reliability of the engine and airplane dynamic components to operate 1200 hours TBO (Time Between Overhaul). This program consists of extensive component fatigue, bench and 1200-hour tie-down tests.

g. Malfunction and failure reporting and analysis:

Three major sources of malfunction and failure reporting systems will be used for reliability analysis.

(1) The standard EIR (Equipment Improvement Recommendation).

(2) The user and logistical interim and final test reports.

F O R O F F I C I A L U S E O N L Y

(3) The comprehensive reliability reporting and contractor analysis which is part of the 1200 hour product improvement program mentioned above.

In addition, continuous analysis of engine and transmission lubricating oil samples will be conducted by the Aviation Test Board Spectrographic Oil Analysis Laboratory.

4. Plans for a Maintainability Program Outlining How Maintainability Will be Achieved.

a. Quantification of maintainability:

Numerical measures of maintainability are being developed by the Aviation Test Board in their logistical evaluation of the CH-47. Data submitted includes time required for maintenance, for inspection, for servicing, for replacement, etc., of both components and systems.

b. Maintainability prediction:

Data is unavailable to date. This will be generated during logistic tests conducted at Fort Rucker.

c. Maintenance task and skill analysis:

A comprehensive maintenance and skill analysis will be conducted as part of the Aviation Test Board 6800-hour logistical evaluation tests. This analysis will be performed in conjunction with the examination of all maintenance functions spelled out in the five-part manual. The skills required at each level, second through fourth echelon will be checked against the maintenance allocation chart (MAC).

d. Maintainability design review:

Contractor's field engineers monitored the complete design of the CH-47 to insure that maintainability was incorporated from the beginning. Initial Air Force and Army maintainability design review was performed during the mock-up inspection in January 1960.

e. Maintainability test and demonstrations:

Initial maintainability demonstration was performed during the three-day airframe and engine Maintenance Engineering Inspection held at Vertol in March 1962. During this demonstration, various components were removed and reinstalled. A comprehensive maintainability test will be conducted as part of the Aviation Test Board 6800-hour logistical evaluation tests. During this test, all possible maintenance functions will be performed and checked against the instructions in the five-part manual.

F O R O F F I C I A L U S E O N L Y

f. Maintenance data collection, feedback and analysis:

(1) Initial maintenance data will be collected by the Aviation Test Board as part of 6800-hour logistical evaluation tests and as a result of maintenance performed on the two Aviation Board aircraft in support of user tests. This data, in the form of weekly maintenance logs, component replacement reports, intermediate and final test reports, will be submitted to and analyzed by AMCPM-CH-CFOE, Air Force, and contractors.

(2) A comprehensive program of collection of maintenance data on representative field aircraft is planned as part of the 1200-hour component product improvement program. This data, which will be collected and analyzed by Vertol, is over and above the EIR (formerly UR) reports submitted to AMCPM-CH-CFOE.

(3) An additional program of collecting and submitting maintenance data is also included as part of the closed cycle overhaul contracts for airframe dynamic components and engines. With the overhaul of each item, the contractor will perform an analytical teardown inspection of the item and report the findings to AMCPM-CH-CFOE. These will be analyzed for the purpose of correcting deficiencies discovered during overhaul and for initiation of modifications required to raise TBOs.

FOR OFFICIAL USE ONLY

1/ FUNDING & CONTRACTS

1. Prior funding, current fiscal year planned obligations and estimated funds necessary to complete the project are shown below:

FY <u>1/</u>	PURPOSE <u>2/</u>	REQUIRED	PROGRAMMED	COMMITTED	OBLIGATED
Prior Fiscal Years 59 60 61 62 63	1. Development	49,659,058	49,659,058	49,659,058	49,209,646
	2. Support	10,379,327	10,379,327	10,379,327	10,311,003
	3. Flight Test	6,650,413	6,650,413	6,650,413	5,885,550
	4. Misc.	3,263,550	3,263,550	3,263,550	3,113,550
	Sub Total	69,952,348	69,952,348	69,952,348	68,519,749
FY 63	<u>3/</u> Overrun (PEMA)	1,147,104	1,147,104	1,147,104	1,147,104
<u>4/</u> Fiscal Year 64	1. Development	1,767,000	1,767,000	1,767,000	/
	2. Support	297,000	297,000	297,000	/
	3. Flight Test				
	4. Misc.	150,000	150,000	150,000	/
	Sub Total	2,214,000	2,214,000	2,214,000	0
TOTAL FY 59-60-61-62-63-64		73,313,452	73,313,452	73,313,452	69,666,853

See Remarks (/) on page **48**

FOR OFFICIAL USE ONLY

Fund Allotment to Date by Appropriation

4/

FUNDING	FY 59	FY 60	FY 61	FY 62	FY 63	FY 64	TOTAL
RDT&E		5,744,690	5,192,429	9,464,323	10,645,000	2,214,000	33,260,442
PEMA (EUT)	25,972,500						25,972,500
PEMA		12,000,000		933,406	1,147,104		14,080,510
Cumulative TOTAL	25,972,500	17,744,690	5,192,429	10,397,429	11,792,104	2,214,000	73,313,452

Proposed Objective Program for F/Y 65

PURPOSE	
1. Development	2,387,000
2. Support	1,500,000
3. Flight Test	1,560,000
4. Miscellaneous	263,000
Total Rqmts	5,710,000

See Remarks (✓) on page 48

FOR OFFICIAL USE ONLY

Remarks:

1/ Prior years include:

MIPR R59-18 (5 YHC-1B development) RDT&E & PEMA (EUT)
MIPR R60-14 (5 JHC-1B and Support) PEMA
MIPR R60-54 (T55 Engine Support) PEMA

- 2/
1. Development includes: 5YCH-47A, 5 JCH-47A mock-up, static test, component tests, ECP's, installed engines, T55 mock-up, ASD test & materiel costs, Repair #1 YHC-1B, overrun and misc. development. For FY 64, includes resolution and correction of service revealed deficiencies encountered during user tests.
 2. Support includes: Airframe/Engine repair parts, overhaul, GSE, GFAE, GFAE ECP's, updating repair parts, spare engines, and Tech Reps.
 3. Flight Test includes: Flight test, Category I & II instrumentation, maintenance of test aircraft, data reduction, and engineering support of flight test.
 4. Miscellaneous includes: Military Characteristics Kit development, TMC RDT&E salaries, TDY, support of "Y" models.

3/ \$1,147,104 is FY 1960 PEMA (MIPR 60-14) portion of June 1962 development overrun, funded.

4/ It is anticipated that an additional amount of \$786,000 will be added to F/Y 64 RDT&E Program bringing the total to 3.0.

F O R O F F I C I A L U S E O N L Y

2. LIST OF MAJOR PRIME CONTRACTS AND CONTRACTORS

ITEM	CONTRACTOR	TYPE	COMPONENT	CONTRACT NO.	PLANNED AM'T OF CONTRACT	OBLIGATIONS THRU 30 NOV 1963
1	Vertol Division Boeing Aircraft Co. Morton, Pennsylvania	Prime	YHC-LB HC-LB Helicopter	AF 33(600) 39492	\$60,590,855	\$58,249,727
2	Lycoming Division AVCO Corporation Stratford, Conn.	Prime	T55-L-5 Shaft Turbine Engine.	AF 33(600) 40108 AF 33(600) 40428	6,960,071 6,507,689	6,770,411 6,116,948
3	Vickers Incorporated Div, Sperry-Rand Corp. Detroit, Michigan	Prime	Hydraulic Starter	AF 33(600) 41955	37,341	37,341
4	Goodyear Tire & Rubber Co. 1144 East Market St. Akron 16, Ohio	Prime	Wheels Brakes	AF 33(600) 41565	9,077	9,077
5	U. S. Rubber Company 66 East Jefferson Detroit 32, Michigan	Prime	Tires	AF 33(600) 60-129 (Procurement Order)	1,787	1,787
6	Jack and Heinz Co. Cleveland, Ohio	Prime	Electrical Components	AF 33(600) 41499	152,457	152,457
7	General Electric Co. Waynesboro, Va.	Prime	Transformer Rectifier	AF 33(600) 41450	9,416	9,416
8	Solar Aircraft Co.	Prime	APU (Spares)	AF 33(657) 7334	68,826	68,826

FOR OFFICIAL USE ONLY

3. List of Major Subcontractors

<u>Subcontractor/Contractor</u>	<u>Type</u>	<u>Component</u>
Hamilton Standard	sub (Lycoming)	Fuel Control
Haynes Stellite	sub (Lycoming)	Turbine Blades (1st stage)
Austen Laboratories, Inc.	sub (Lycoming)	Turbine Blades (2nd & 3rd stage)
Heintz	sub (Lycoming)	Liner, Vaporizer, Scope, Support & Housing Assys
Stalker Development Corp.	sub (Lycoming)	Compressor Vane Assembly
Western Gear	sub (Lycoming)	Accessory Gear Assembly
Utica Drop Forge	sub (Lycoming)	Compressor Blades
Dynamic Filter Inc.	sub (Lycoming)	Fuel Purifier
PESCO	sub (Lycoming)	Lubrication Pump
Aircraft Engineering Products	sub (Vertol)	Extensible Links, Ramps, Actuating Cylinders
Aluminum Company of America	sub (Vertol)	Raw Aluminum
Bewley Engineering & Manufacturing Company	sub (Vertol)	Actuators, Manifolds
Comprehensive Designers, Inc.	sub (Vertol)	Engineering Service
Consolidated Industries, Inc.	sub (Vertol)	Forgings
Development Designers Co., Inc.	sub (Vertol)	Engineering Service
Foote Brothers	sub (Vertol)	Transmissions, Gears
Hydra Power Corporation	sub (Vertol)	Valves, Pumps, Actuators, Hydraulics
Jarry Hydraulics Limited	sub (Vertol)	Landing Gears
John Bertram & Sons Co., Ltd.	sub (Vertol)	Test Stands
Lear, Inc.	sub (Vertol)	Gyros, Indicators, Pumps
Lycoming Division, AVCO Corp.	sub (Vertol)	Rotor Hub Parts
SKF Industries, Inc.	sub (Vertol)	Bearings
Solar Aircraft Company	sub (Vertol)	Auxiliary Power Units
Tube Reducing Corp.	sub (Vertol)	Spar Tubes
Vickers, Incorporated	sub (Vertol)	Pumps, Valves

FOR OFFICIAL USE ONLY

APPENDIX I

DISTRIBUTION LIST

	No. of Copies
Director of Defense Research & Engineering Department of Defense Washington D. C. 20301	20
Chief of Research and Development Department of the Army Washington D. C. 20310	7
Director Central Intelligence Agency Washington D. C. 20505	1
Assistant Chief of Staff for Intelligence ATTN: Systems Developments Div Department of the Army Washington D. C. 20310	1
Asst Chief of Staff for Force Development ATTN: Materiel Development Div Department of the Army Washington D. C. 20310	1
Deputy Chief of Staff for Logistics ATTN: Requirements Div Department of the Army Washington D. C. 20310	1
The Surgeon General Department of the Army Washington D. C. 20315	2
Chief of Naval Operation ATTN: OP-90-J Department of the Navy Washington D. C. 20350	3
Documentation Center for Scientific & Technical Information, Defense ATTN: RDTE Information Div DDC-IM Cameron Station Alexandria, Virginia 22314	1

FOR OFFICIAL USE ONLY

DISTRIBUTION (Cont'd)

No. of Copies

Commanding General	
U. S. Army Materiel Command	
Washington D. C. 20315	
ATTN: AMCPM-CH	2
AMCMR	1
AMCRD-C	1
AMCRD-SR	4
AMCAD-AS, ATTN: Sec 4 For AMCRD-S	1
AMCAD-AS, ATTN: DW-BX For AMCRD-S	1
AMCAD-AS, ATTN: AD For AMCRD-S	1
Commanding General	10
U. S. Army Mobility Command	
Warren, Michigan 48090	
Commanding General	3
U. S. Army Missile Command	
ATTN: AMSMI-FP	
Redstone Arsenal, Alabama 35809	
Commanding General	10
U. S. Army Weapons Command	
ATTN: Technical Information Branch	
Rock Island Arsenal	
Rock Island, Illinois 61202	
Commanding General	10
U. S. Army Munitions Command	
Dover, N. J. 07801	
Commanding General	10
U. S. Army Electronics Command	
Fort Monmouth, New Jersey 07703	
Commanding General	20
U. S. Army Test & Evaluation Command	
Aberdeen Proving Ground, Maryland 21005	
Commanding General	
U. S. Army Supply & Maintenance Command	
Washington D. C. 20315	
ATTN: AMSSM-MR-M	1
AMSSM-SX-P	1

FOR OFFICIAL USE ONLY

DISTRIBUTION (Cont'd)

No of Copies

Commanding General U. S. Army Combat Developments Command ATTN: CDCMR Fort Belvoir, Virginia 22060	1
Commanding General U. S. Continental Army Command Fort Monroe, Virginia	3
Commanding Officer U. S. Army Limited War Laboratory Aberdeen Proving Ground, Maryland 21005	1
Director U. S. Army Engineer Geodesy, Intelligence and Mapping Research and Development Agency Fort Belvoir, Virginia 22060	1
Commanding Officer U. S. Army Engineer Waterways Experiment Station Vicksburg, Mississippi	1
Chief of Engineers Department of the Army Washington, D. C.	1
Commanding General U. S. Army Security Agency Washington, D. C.	2
Commanding Officer U. S. Army Research Office Durham, North Carolina	1
Commanding Officer U. S. Army Ballistics Research Laboratories Aberdeen Proving Ground, Maryland 21005	2
Commanding Officer U. S. Army Human Engineering Laboratory Aberdeen Proving Ground, Maryland 21005	1
Commanding Officer U. S. Army Coating & Chemical Laboratory Aberdeen Proving Ground, Maryland 21005	1

FOR OFFICIAL USE ONLY

DISTRIBUTION (Cont'd)

No of Copies

Commanding General U. S. Army Natick Laboratories Natick, Massachusetts	3
Commanding Officer U. S. Army Materials Research Agency ATTN: Technical Information Center Watertown, Massachusetts	2
Commanding Officer Harry Diamond Laboratory Washington D. C. 20438	2
Commanding Officer U. S. Army Cold Regions Research & Engineering Laboratory Hanover, New Hampshire	1
Commanding Officer U. S. Army Nuclear Defense Laboratory Edgewood Arsenal, Maryland 21010	1
Commanding General U. S. Army Medical R&D Command ATTN: Records & Reports Branch Main Navy Building Washington D. C. 20360	1
Quartermaster Hq, XVIII Airborne Corps Fort Bragg, North Carolina	1
U. S. Army Standardization Group Box 65, USN 100, FPO New York, New York	2
Command U. S. Army Command & General Staff College Fort Leavenworth, Kansas	2
President U. S. Army Maintenance Board Fort Knox, Kentucky	2
Commanding General Defense Clothing & Textile Supply Center Defense Supply Agency 2800 South 20th Street Philadelphia, Pennsylvania	9

FOR OFFICIAL USE ONLY

DISTRIBUTION (Cont'd)

No of Copies

Executive Director Defense Subsistence Supply Agency 226 W. Jackson Blvd Chicago, Illinois	3
Commanding Officer Defense General Supply Agency Richmond 12, Virginia	1
Chief of Naval Research (Code 104) Department of the Navy Washington, D. C. 20390	1
Chief, Bureau of Medicine & Surgery Research Division (Code 71) Department of the Navy Washington D. C. 20390	1
Commandant, Marine Corps (Code AX) Washington D. C. 20380	1
Director Army Research Office ATTN: Human Factors Research Division 3045 Columbia Pike Arlington 4, Virginia	1
Director Human Resources Research Office 300 N. Washington Street Alexandria, Virginia	1
Commandant U. S. Army Quartermaster School Fort Lee, Virginia	1
Director U. S. Army Personnel Research Office Washington D. C. 20315	1
Director Special Operations Research Office The American University 4501 Massachusetts Avenue, N. W. Washington D. C.	1

FOR OFFICIAL USE ONLY

DISTRIBUTION (Cont'd)

No of Copies

University of Pittsburgh
 Army Materiel Research Staff
 1776 Massachusetts Avenue, N. W.
 Washington D. C.

1

Air Force Systems Command
 ATTN: AFSC-STLO-LN
 c/o Department of the Navy
 Room 2305
 Munitions Building
 Washington D. C. 20333

1

Commanding Officer
 U. S. Army Avionics Field Office
 ATTN: SELVL-AH
 12th and Spruce Streets
 St Louis, Missouri

1

Commanding Officer
 U. S. Army Transportation Research Command
 Fort Eustis, Virginia

3

Chief
 U. S. Army Aviation & Surface Materiel Command
 Aviation Test Office
 ATTN: FLZAT
 Edwards Air Force Base, California

2

Chief
 U. S. Army Aviation & Surface Materiel Command
 Air Force Coordinating Office
 ATTN: ASDKA
 Wright-Patterson Air Force Base, Ohio

1

Chief
 U. S. Air Force Systems Command
 Aeronautical Systems Division
 ATTN: ASZTF
 Wright-Patterson Air Force Base, Ohio

2

Commanding Officer
 U. S. Army Combat Developments Command Liaison Officer
 12th and Spruce Streets
 St. Louis, Missouri

1

Commanding Officer
 U. S. Army Medical Equipment R&D Laboratory
 Fort Totten, Flushing
 Long Island, New York

1

FOR OFFICIAL USE ONLY

DISTRIBUTION (Cont'd)	No of Copies
Commanding General U. S. Army Institute of Advanced Studies Carlisle Barracks, Pennsylvania	1
Commanding General U. S. Army Combined Arms Group Fort Leavenworth, Kansas	1
Commanding Officer U. S. Army Artillery Combat Developments Agency Fort Sill, Oklahoma	1
Commanding Officer U. S. Army Aviation Combat Developments Agency Fort Rucker, Alabama	1
Commanding Officer U. S. Army Engineer CD Agency Fort Belvoir, Virginia	1
Commanding Officer U. S. Army Infantry Combat Developments Agency Fort Benning, Georgia	1
Commanding Officer U. S. Army Intelligence Combat Developments Agency Fort Holabird, Maryland	1
Commanding Officer U. S. Army CBR Combat Developments Agency Fort McClellan, Alabama	1
Commanding Officer U. S. Army Communications-Electronics Combat Developments Agency Fort Huachuca, Arizona	1
Commanding Officer U. S. Army Combined Arms Combat Developments Agency Fort Leavenworth, Kansas	1
Commanding Officer U. S. Army Air Defense Combat Developments Agency Fort Bliss, Texas	1
Commanding Officer U. S. Army Armor Combat Developments Agency Fort Knox, Kentucky	1

FOR OFFICIAL USE ONLY

DISTRIBUTION (Cont'd)

No of Copies

Commanding General U. S. Army Combat Developments Experimentation Center Fort Ord, California	1
Commanding Officer U. S. Army Office of Special Weapons Development Fort Bliss, Texas	1
Commanding Officer U. S. Army Special Doctrine & Equipment Group Fort Belvoir, Virginia 22060	1
Commanding Officer U. S. Army Special Warfare Combat Developments Agency Fort Bragg, North Carolina	1
Commanding Officer U. S. Army Combat Service Support Group Fort Lee, Virginia	1
Commanding Officer U. S. Army Adjutant General Combat Developments Agency Fort Benjamin Harrison Indianapolis 16, Indiana	1
Director U. S. Army Chaplain Combat Developments Agency Fort Lee, Virginia	1
Commanding Officer U. S. Army Medical Service Combat Developments Agency Fort Sam Houston, Texas	1
Commanding Officer U. S. Army Military Police Combat Developments Agency Fort Gordon, Georgia	1
Commanding Officer U. S. Army Quartermaster Combat Developments Agency Fort Lee, Virginia	1
Commanding Officer U. S. Army Transportation Combat Developments Agency Fort Eustis, Virginia	1
Commanding Officer U. S. Army Ordnance Combat Developments Agency Aberdeen Proving Ground, Maryland 21005	1
Commanding Officer, U. S. Army Civil Affairs Combat Developments Agency Fort Gordon, Georgia	1

FOR OFFICIAL USE ONLY

DISTRIBUTION (Cont'd)

No of Copies

Commanding Officer U. S. Air Force Air Weather Service (MATS) Scott Air Force Base, Illinois	1
Headquarters Seventh Army ATTN: AETQM-O APO 46, New York, N. Y.	1
Director Marine Corps Landing Force Development Center Marine Corps Schools Quantico, Virginia (ATTN: Plans and Operations Division)	5
Marine Corps Liaison Officer USAMC ATTN: AMCGS-LN-F Washington D. C. 20315	1
Commanding Officer ATTN: STEAP-DS-D Aberdeen Proving Ground, Maryland 21005	1
Commanding General Hq, Quartermaster Research & Engineering Field Evaluation Agency, U. S. Army Fort Lee, Virginia	1
Commanding General Hq, U. S. Army Combat Development Command Combined Arms Group Fort Belvoir, Virginia 22060	1
Commanding Officer U. S. Army Foreign Science & Technology Center ATTN: Technical Data Branch Arlington Hall Station Washington D. C., 20025	1
Headquarters Office of Aerospace Research, USAF ATTN: RRO 4th & Independence Avenue, N. W. Washington D. C. 20315	1

FOR OFFICIAL USE ONLY

DISTRIBUTION (Cont'd)

No of Copies

Commanding General U. S. Army Materiel Command ATTN: AMCMU-IS Washington, D. C. 20315	1
Director Advanced Research Projects Agency ATTN: FA Koether, The Pentagon Room 2B263 Washington D. C. 20301	1
Army Representative Amphibious Warfare Evaluation Board, Pacific c/o COMPHIBTRAPAC, U. S. Naval Amphibious Base, Coronado San Diego, California 92155	1
Chief of Naval Material Code MAT-31 Department of the Navy Washington D. C. 20360	1
Chief of Naval Operations Code 07-T-10 Department of the Navy Washington, D. C. 20350	1
Research Analysis Corporation McLean, Virginia 22101	1

FOR OFFICIAL USE ONLY

APPENDIX II

DETAILED TECHNICAL REPORTS

1. TCTC Item 1882, Meeting 106, held 1 November 1956, Development Project 9-38-04-00, Mobility Aircraft; initiation approved.
2. Comment Nr. 1, CDR to the Technical Services, subject: "Research and Development Program Directive, file CDR/A 81, dated 7 January 1957; directing development of subject item.
3. Letter, ATDEV-6 400.114/14 (c) (24 Apr 57), HQ USCONARC to CDR, subject: "US CONARC Approved MCs for Helicopter, Transport, Medium, New (U)," forwarding MCs for subject item.
4. TCTC Item 2133, Meeting 111, held September 1957, Sub-task 508AV, Project 9-38-04-00, Medium Transport Helicopter (2 Ton); initiation approved. (Subsequently redesignated as Task 508AV.)
5. TCTC Item 2167, Meeting 111, held 5 September 1957, approval of military characteristics.
6. TCTC Record and Information Item 2885, Meeting 117, held 21 August 1958, Redesignation to Projects of Tasks Included in the FY 1959 Aircraft Program, redesignating Task 508AV Project 9-38-04-000 as Project 9-38-13-012.
7. Letter to CRD, subject: "Military Characteristics for a New Transport Helicopter," file ATDEV-6 400-114/54 (28 Apr 59), dated 28 April 1959, recommending approval of military characteristics for subject item.
8. D/F, Comment Nr. 1, to Chief of Transportation, subject: "Military Characteristics for a New Transport Helicopter," file CRD/H 4264, dated 13 May 1959, approving MCs recommended by ref 21d(7) which superseded MCs approved by Ref 21d(5).
9. TCTC Record and Information Item 3128, Meeting 123, held 2 July 1959, Helicopter, Transport, New (U); approved military characteristics recorded; Helicopter, Transport, Medium, New (U); supersession of military characteristics.
10. TCTC Record and Information Item 3206, Meeting 124, held 24 July 1959, Helicopter, Transport, Medium, HC-1B; type classification as Limited Production (L).

F O R O F F I C I A L U S E O N L Y

11. Vertol Report Nr. SR-416, Development Engineering Inspection, YHC-1B preliminary cockpit mock-up, dated 19-20 November 1959.
12. TCTC Record and Information Item 3313, Meeting 126, held 17 December 1959, Renumbering of Transportation Corps Research and Development Projects and tasks; Changes in Titles.
13. Report of Mock-up Board Proceedings on the YHC-1B Helicopter Contract AF 33(600)39492, dated 29 January 1960 by Deputy for Airborne Support Systems, Directorate of Systems Management, Wright Air Development Division.
14. Letter Hq, WADD, ARDC, USAF, W-P AFB, Ohio, dated 3 February 1960, subject: "YHC-1B Army Helicopter (Chinook) - Initial Development Coordination Conference; "submitting minutes of conference held at Wright-Patterson AFB on 7 January 1960.
15. Letter, Hq, WADD, ARDC, USAF, W-P AFB, Ohio, dated 22 March 1960, subject: "YHC-1B Helicopter Meeting - Loading Ramp, Personnel Door, and APU;" submitting report of meeting held at Vertol on 3 March 1960.
16. TCEXP-S Minutes of First System Management Meeting, dated 30 March 1960, issued 16 May 1960.
17. Letter WADD (WWZTB), dated 13 May 1960, subject: "Development Engineering Inspection on YHC-1B Helicopter Cockpit Lighting;" submitting minutes of cockpit lighting mock-up held at Vertol on 5 May 1960.
18. Letter to Chief of Research and Development, dated 7 July 1960, subject: "Helicopter Skis."
19. Vertol Monthly Progress Reports, Nr. 1, dated 20 July 1959 and all monthly reports thereafter through March 1963.
20. Vertol Semi-Annual Technical Report Nr. 1, December 1959, dated 22 January 1960 and all Semi-Annual Technical Reports thereafter through December 1962.
21. Lycoming Monthly Progress Report Nr. 1, dated 31 August 1960 through Report Nr. 25, dated 25 October 1961.
22. Vertol Report Nr. 114-X-01, Detail Specifications for the Model YHC-1B Helicopter, dated 22 June 1959, Revision E, 15 November 1962.
23. TCEXP-S, Minutes of Second System Management Meeting, HC-1B, Chinook, dated 26 October 1960, issued 15 December 1960.

24. TCEXP-S Minutes of Third System Management Meeting, HC-1B and H-37, dated 19 April 1961, issued 8 May 1961.
25. Vertol Report Nr. 114-X-101, Detail Specifications for Model HC-1B helicopter, dated 6 June 1960, Revision C, 31 December 1962 (FY 61 Procurement).
26. Vertol Report Nr. 114-X-201, Detail Specifications for Model HC-1B helicopter, dated 18 May 1961, Revision B, 8 March 1963. (FY 62 Procurement).
27. Lycoming Report Nr. 729.6.4, 150-hour penalty test, dated 10 January 1961.
28. Technical Development Plan, HC-1B Suppressive Fire, 6 April 1961.
29. TCTM Item 3740 Meeting 137 Report, dated 15 June 1961. Establishment of December 1962 for Standard "A" for HC-1B Chinook Helicopter.
30. Plan for Test and Evaluation, HC-1B Chinook, revised 24 July 1962. (PHASE "F").
31. Minutes of Flight Safety Inspection, dated 6-7 July 1961.
32. Final Report of Accident - YHC-1B Helicopter, dated 31 July 1961.
33. Report on conference on Chinook helicopter reprogramming held at OCOFT, 14 August 1961.
34. TMC Semi-Annual Review and Status Report, 1st Half, FY 62, HC-1B Helicopter.
35. TCEXP-S Minutes of Fourth Systems Management Meeting, 18 October 1961, issued 21 November 1961.
36. Minutes of HC-1B Maintenance Engineering Inspection (MEI) conducted at Vertol on 7, 8 and 9 March 1962, Change 1 of minutes dated 16 April 1962.
37. TCEXP-S Minutes of Limited Systems Management Meeting, 17 January 1962, issued 23 February 1962.
38. U. S. Army Aviation Board Plan of Test, Project Number AVN 162, Service Test of the HC-1B Helicopter, dated 13 February 1962.
39. ASD HC-1B Category I and II Engineering Test Plans submitted to TMC for review and approval, dated 25 January 1962. Army revised and approved Engineering Test Plan returned to ASD, 9 March 1962.

40. TCEXP-S Minutes of Systems Management Meeting, 18 April 1962, issued 16 May 1962.

41. Minutes of Fifth HC-1B Systems Coordinating Group Meeting, Eglin AFB, Florida, 11-12 June 1962.

42. Minutes of HC-1B Contractor Technical Compliance Inspection (CTCI) conducted at Vertol on 18, 19 and 20 July 1962.

43. Minutes of Sixth HC-1B Systems Coordinating Group Meeting, 16-17 August 1962 at Lycoming.

44. TMC Semi-Annual Review and Status Report, 2nd Half, FY 62, HC-1B Helicopter.

45. ASD Report, System Program Management Survey, conducted 25 July - 9 August 1962 by the Air Force.

46. Minutes of HC-1B TBO meeting, 21-22 August 1962 at ASD.

47. Minutes of Seventh CH-47A Systems Coordinating Group Meeting, 28 September 1962, at Vertol.

48. Minutes of Eighth CH-47A Systems Coordinating Group Meeting, 27-28 November 1962 at ASD.

49. Minutes of the Ninth CH-47A Systems Coordinating Group Meeting, 15-16 January 1963, at AMC, Washington, D. C.

50. Vertol Report Nr. 114-X-301, Detail Specifications for Model CH-47A Helicopter, dated 15 January 1963. (FY 63 Procurement)

51. Minutes of CH-47A TBO meeting, 17 January 1962, at AMC.

52. Minutes of the Tenth CH-47A Systems Coordinating Group Meeting, 20-22 March 1963, at Aviation Test Board, Fort Rucker, Alabama.

53. ASD Report, Category II Extreme Temperature Evaluation of a YHC-1B Helicopter (YCH-47A) in the Climatic Laboratory, dated March 1963.

54. Minutes of the Eleventh CH-47A Systems Coordinating Group Meeting, 15-16 May 1963, at AVSCOM, St. Louis, Mo.

55. Revised Test Plan - Service Test (Phase E) and Logistical Evaluation (Phase F) of the CH-47A Chinook Helicopter, 7 June 1963, by Aviation Test Board, Fort Rucker, Alabama.

56. Minutes of the Twelfth CH-47A Systems Coordinating Group Meeting
17-18 July 1963 at Lycoming, Stratford, Conn.

57. Letter AVSCOM, dated 6 Sep 63, subject: "CH-47A CHINOOK Helicopter,
Resolution of Reported Deficiencies Prior to Type Classification" submitting
review of TEC test report together with the status of all reported deficiencies.

58. Minutes of the Thirteenth CH-47A Systems Coordinating Group Meeting
18-19 Sept 63 at U. S. Army Mobility Command, Warren, Michigan.

59. Minutes of CH-47A Maintenance Package Review Meeting 9-18 Sept 63
at Ft Rucker, Alabama.

60. Minutes of CH-47A TBO meeting 19-20 Nov 63 at ASD.

61. Minutes of TCTC meeting at Washington, D. C. at which CH-47A was
type classified on 25 October 1963.

F O R O F F I C I A L U S E O N L Y

